

ASSEMBLY INSTRUCTION

Thank you for your purchase. Please follow the instructions below for correct assembly.

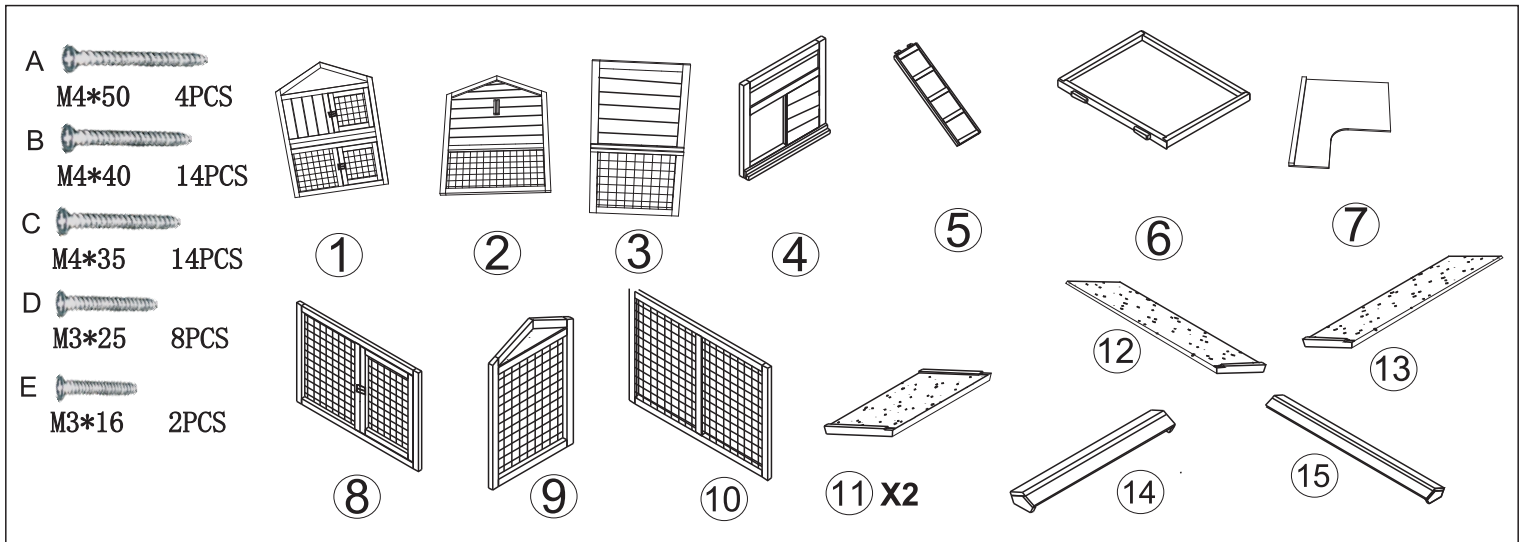

Step 1

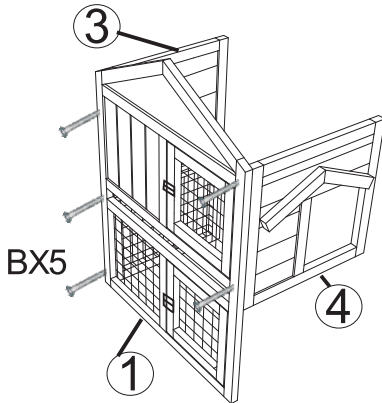

Attach side panel part ③ and middle panel part ④ to front panel part ①, secure with 5x screw (B).

Step 2

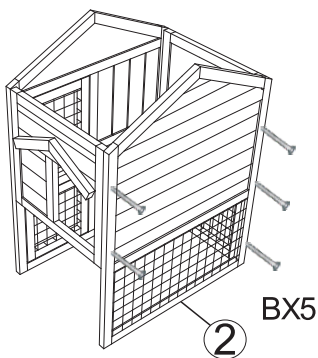

Secure back panel part ② with 5x screw (B).

Step 3

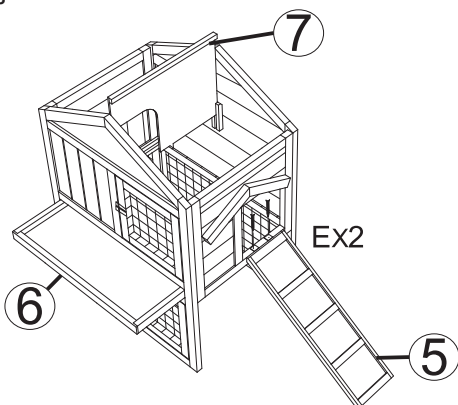

Put in metal tray part ⑥, and insert part ⑦ from top as shown.

Attach ramp part ⑤ to middle panel, secure with 2x screw (E).

Step 4

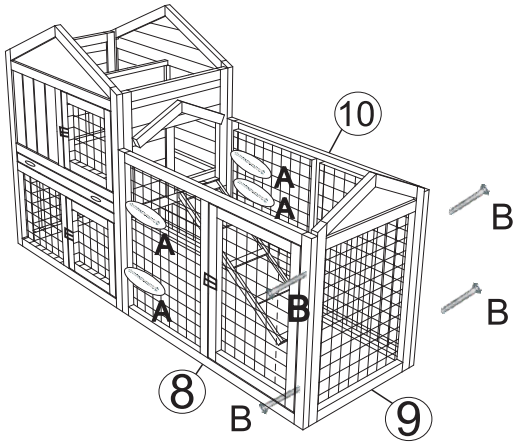

Attach part ⑧ and part ⑩ to the main house finished in the above steps, each secured with 2x screw (A).

Secure part ⑨ by using 2x screw (B) on each side.

Step 5

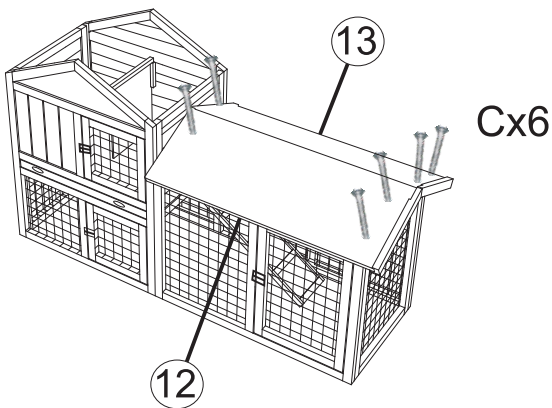

Attach roofs part ⑫ and part ⑬, secure with 6x screw (C) as pictured.

Step 6

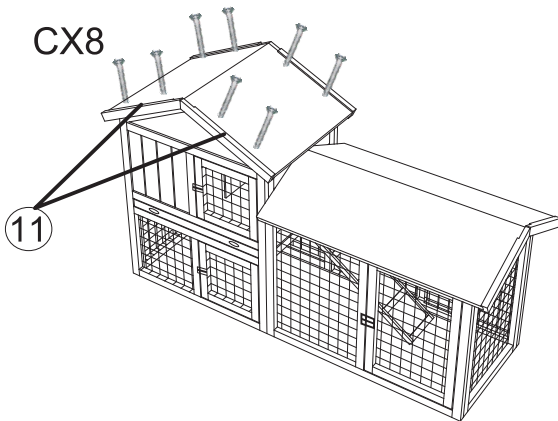

Attach 2x roofs part ⑪, secure with 8x screw (C).

Step 7

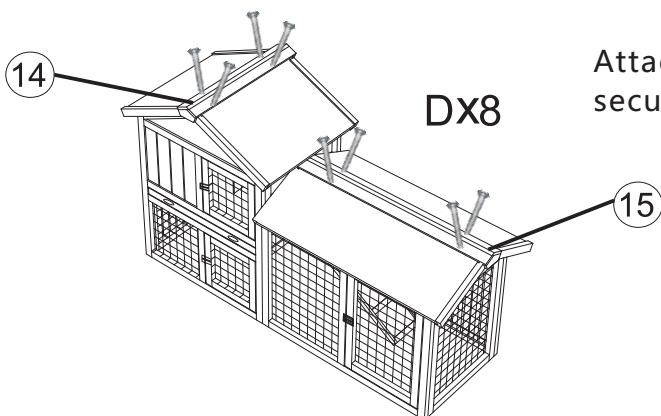

Attach part ⑭ and part ⑮ to roof respectively, each secured with 4x screw (D), total using 8x screw (D).

RETURN / DAMAGE CLAIM INSTRUCTIONS

1. **DO NOT** discard of the box / original packaging.

In case a return is required, the item must be returned in original box. Without this your return will not be accepted.

2. Take a photo of the box markings.

A photo of the markings (text) on the box is required in case a part is needed for replacement. This helps our staff identify your product number to ensure you receive the correct parts.

3. Take a photo / Video of Damage (if applicable).

A photo /Video of the damage is always required to file a claim and get your replacement or refund processed quickly. Please make sure you have the box even if it is damaged.

4. Send us an email with the images requested.

Email us directly with the attached images, order number (SOXXXX) and a description of your claim.

Auckland / Waikato / BOP Branch: sales@tsbliving.co.nz

Christchurch Branch: customersupport@tsbliving.co.nz

Wellington Branch: wellington@tsbliving.co.nz