

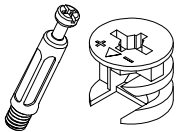







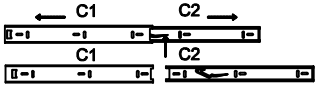

<p><b>A</b> 71pcs</p> 	<p><b>B</b> 7pcs</p> 	<p><b>C</b> 5pcs</p> 	<p><b>D</b> 66pcs</p> <p>14*3.5</p> 	<p><b>E</b> 4pcs</p> 	<p><b>F</b> 34pcs</p> <p>35*3.5</p> 	<p><b>G</b> 6pcs</p> 
<p><b>H</b> 2pcs</p> 	<p><b>I</b> 60pcs</p> 	<p><b>J</b> 8pcs</p> 	<p><b>K</b> 4pcs</p> 	<p><b>L</b> 2pcs</p> 	<p><b>M</b> 2pcs</p> 	<p><b>N</b> 7pcs</p> 

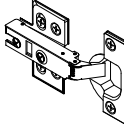
1

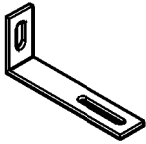

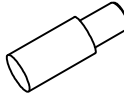
Remove c2 from c1 by sliding it out and pressing on the catch as indicated.

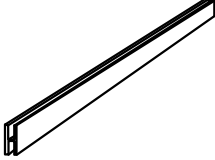
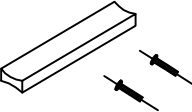
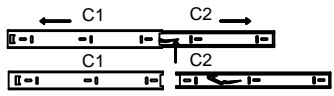
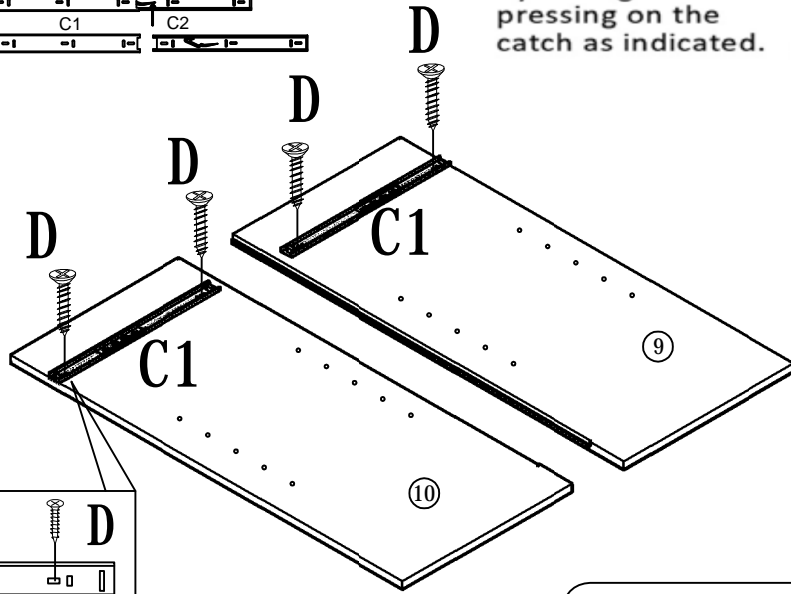

C1\*2 D\*4

2

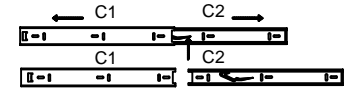

Remove c2 from c1 by sliding it out and pressing on the catch as indicated.

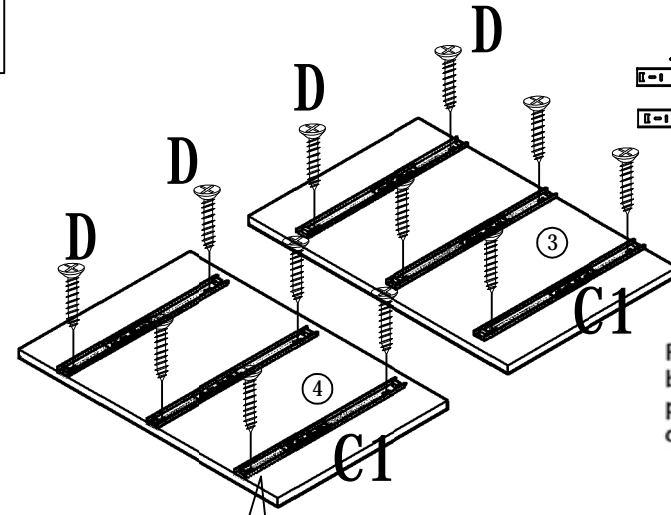

C1\*6 D\*12

3

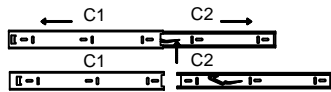

Remove c2 from c1 by sliding it out and pressing on the catch as indicated.

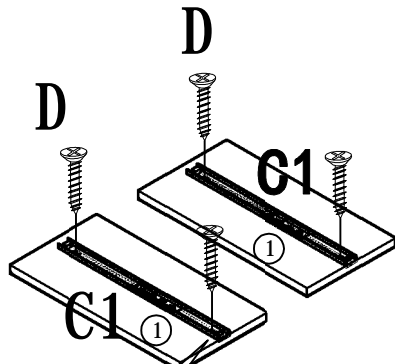

C1\*2 D\*4

4

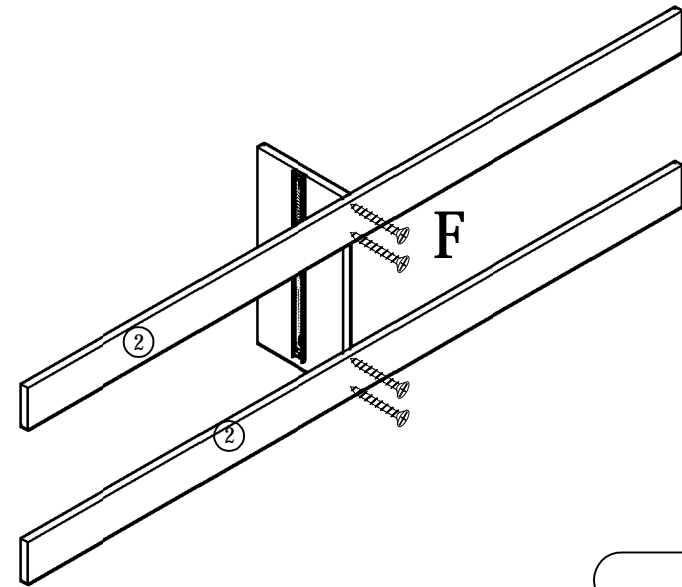

F\*4

5

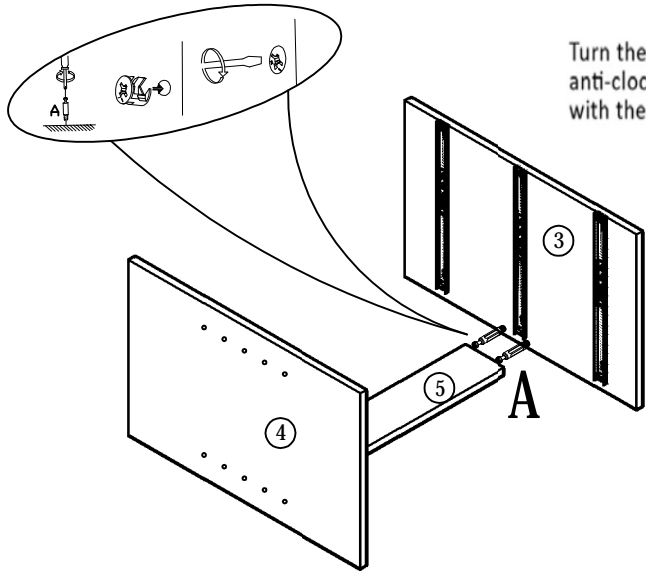

Turn the sub-assembly around anti-clockwise and set it flat down with the shelf opening facing the front

A\*4

6

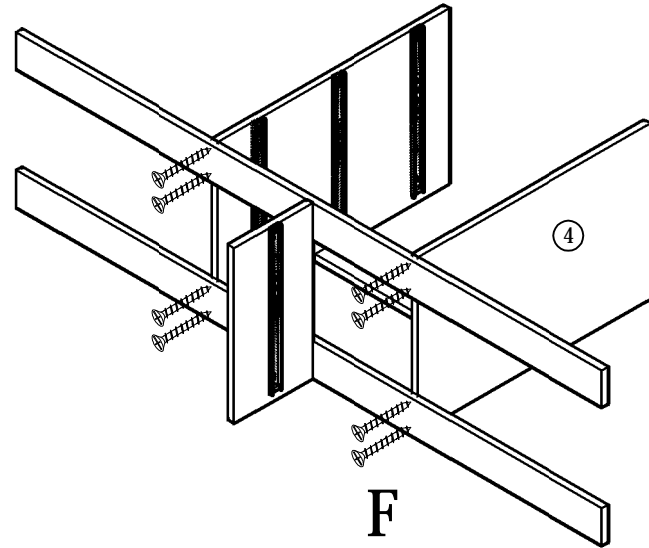

F\*8

7

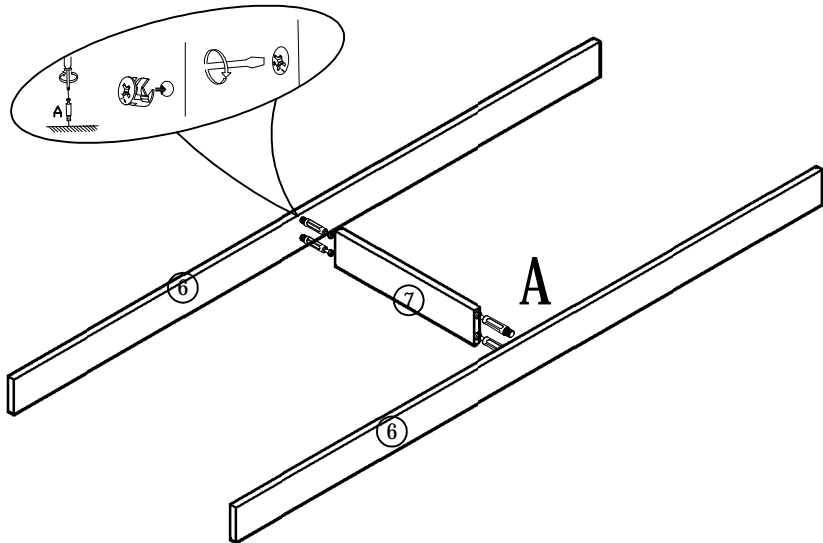

A\*4

8

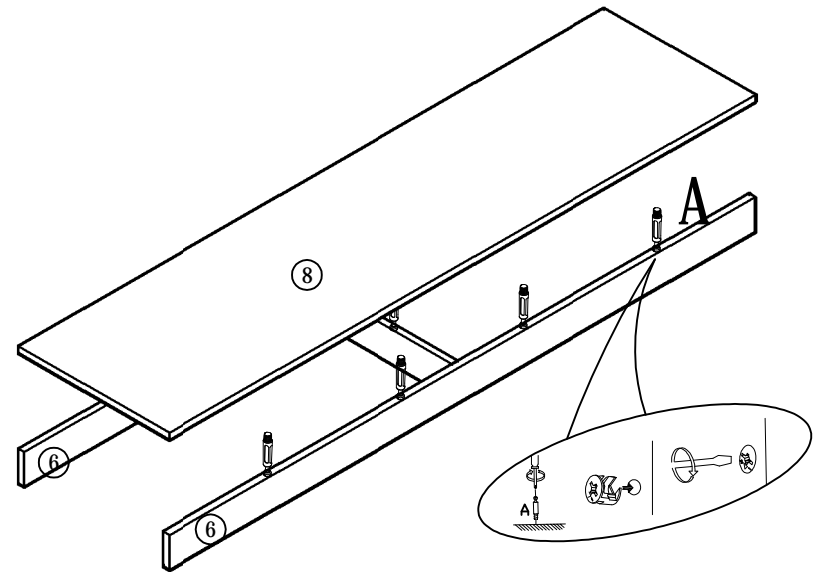

A\*9

9

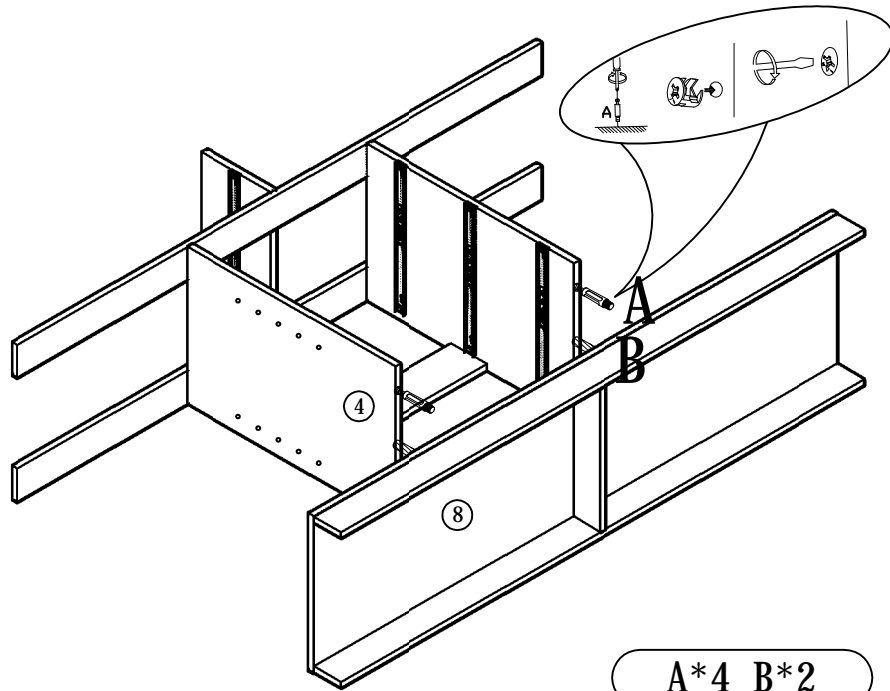

A\*4 B\*2

10

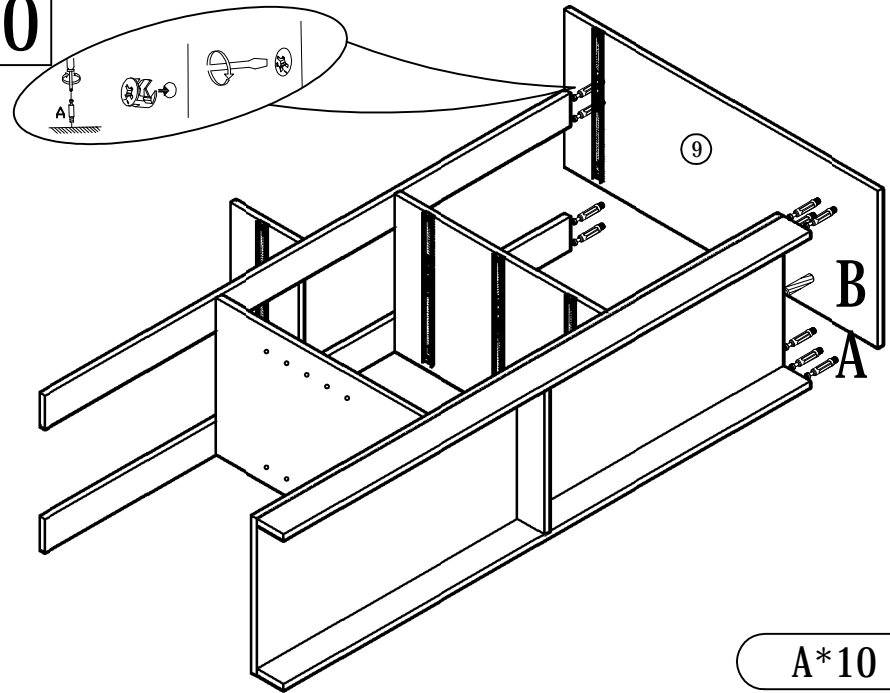

A\*10 B\*1

11

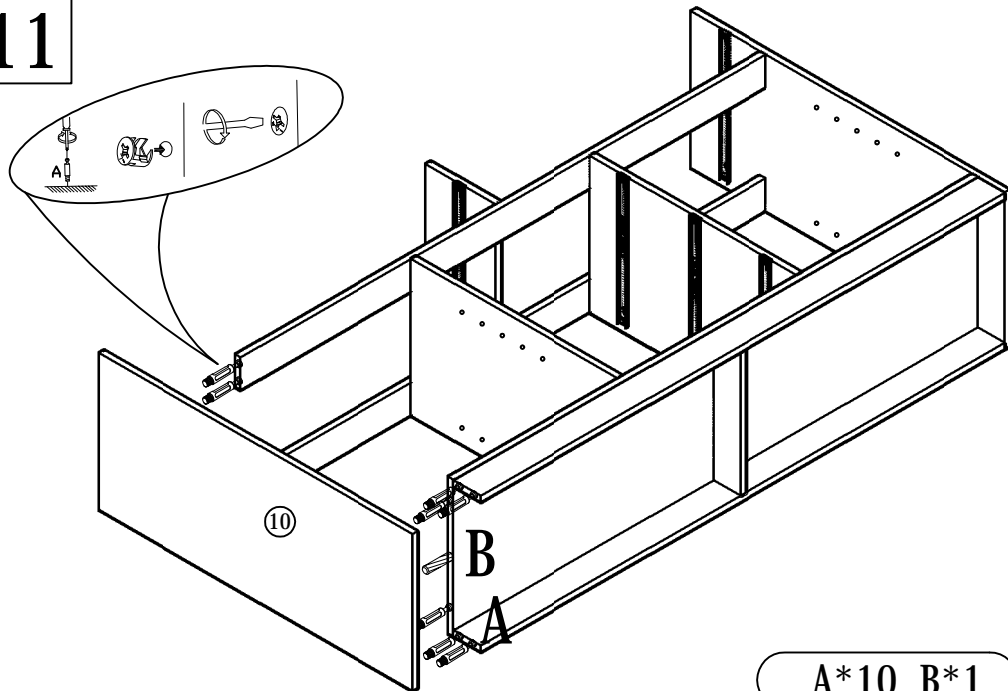

A\*10 B\*1

12

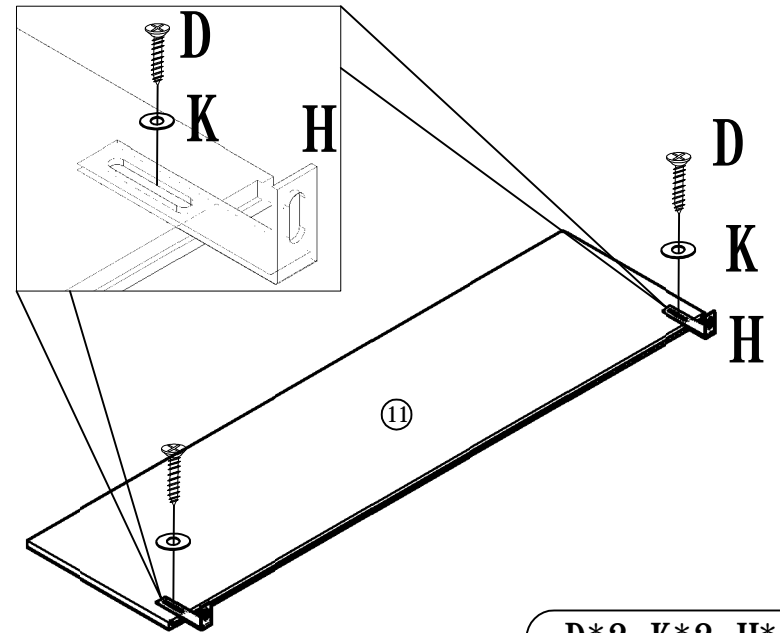

D\*2 K\*2 H\*2

13

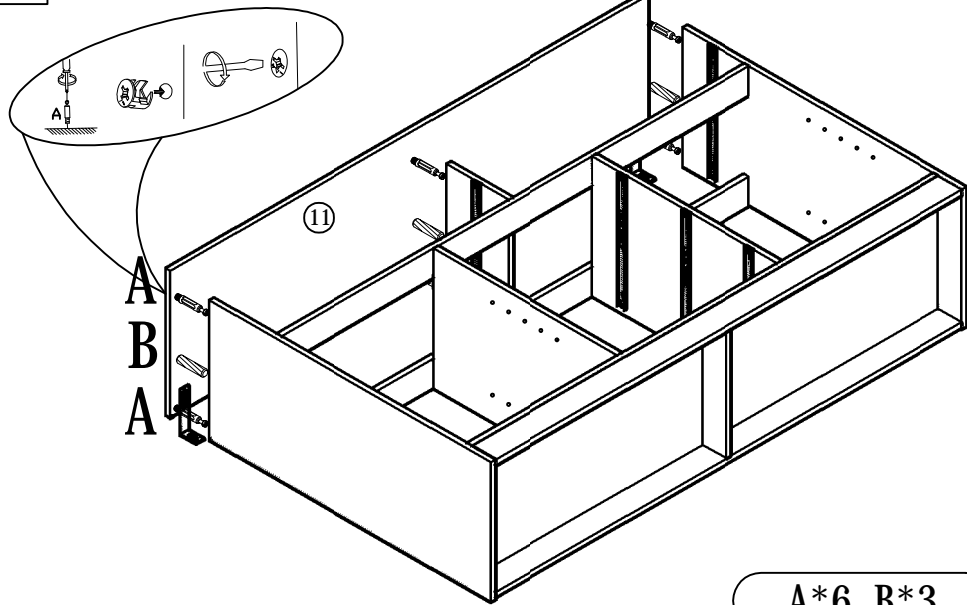

A\*6 B\*3

14

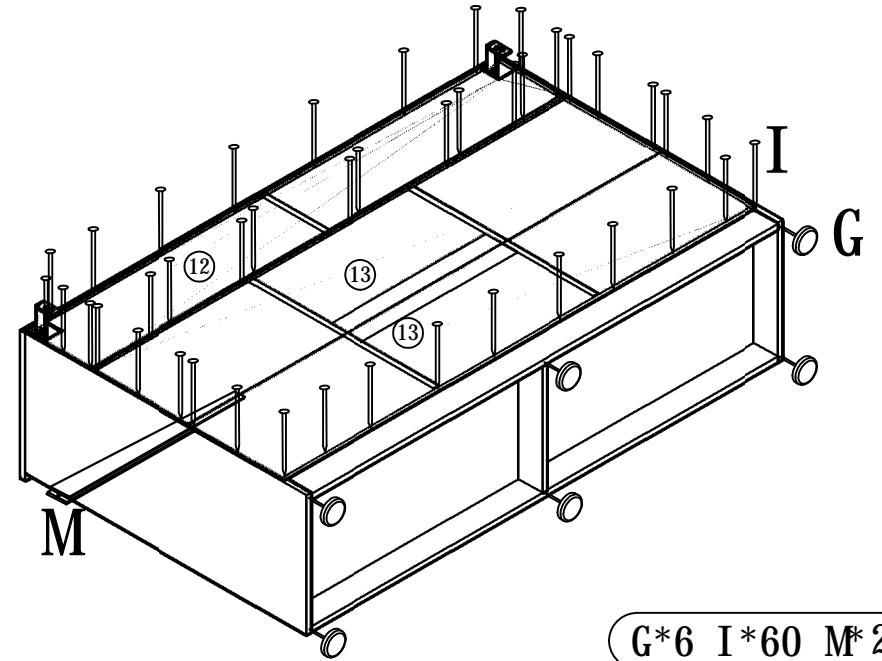

G\*6 I\*60 M\*2

15

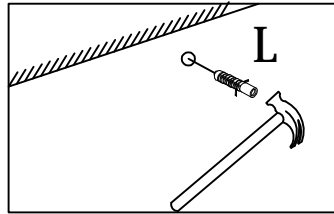

Pre-drilled holes in wall.

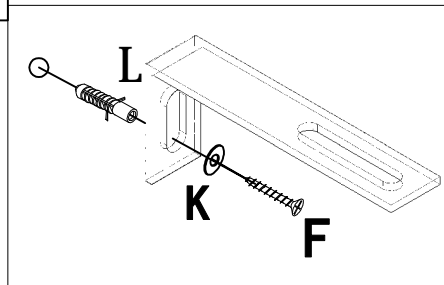

Secure K to wall with screw F.

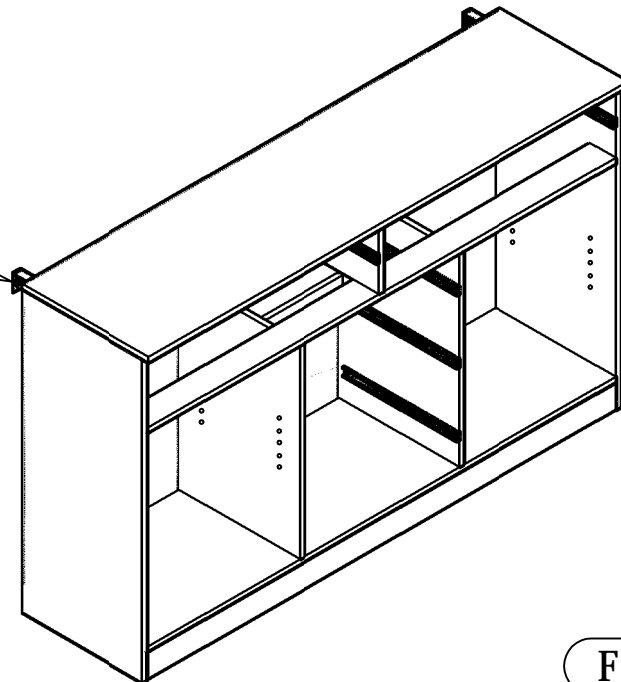

F\*2 K\*2 L\*2

16

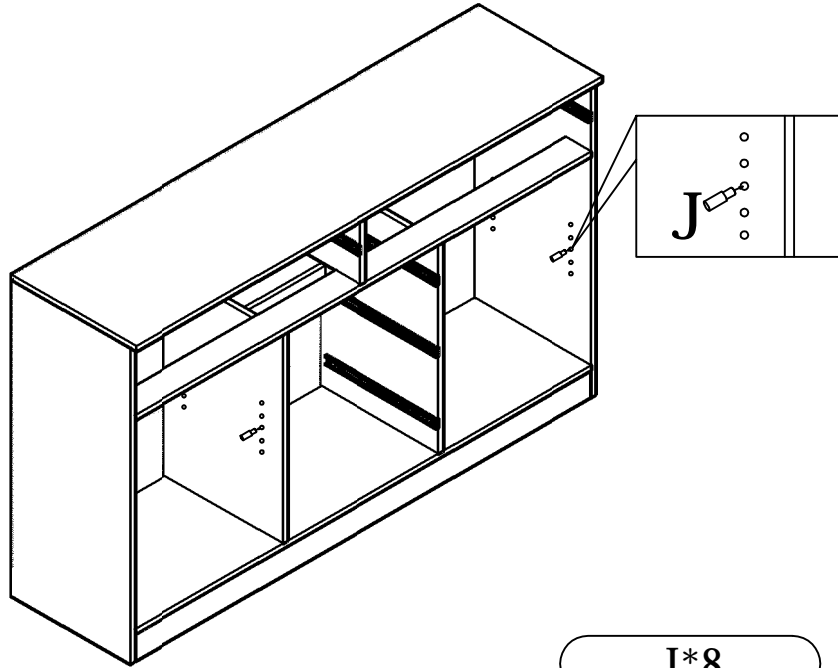

J\*8

17

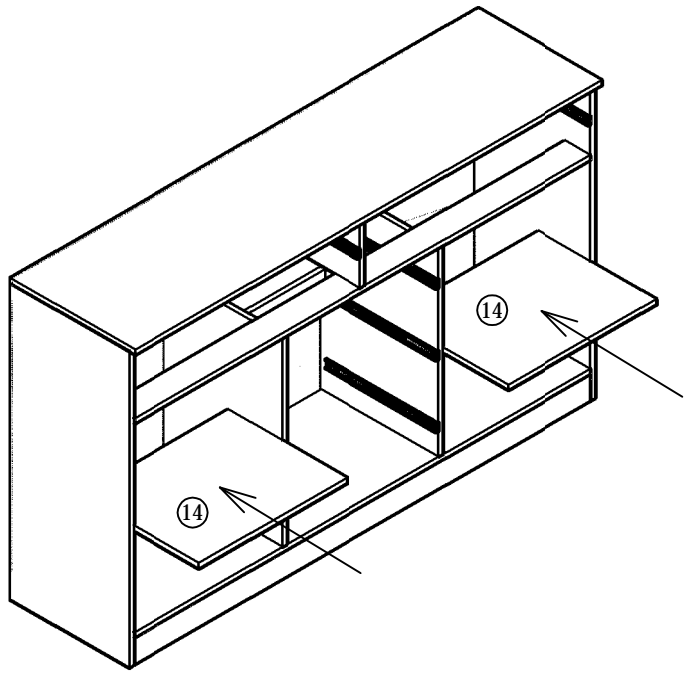

18

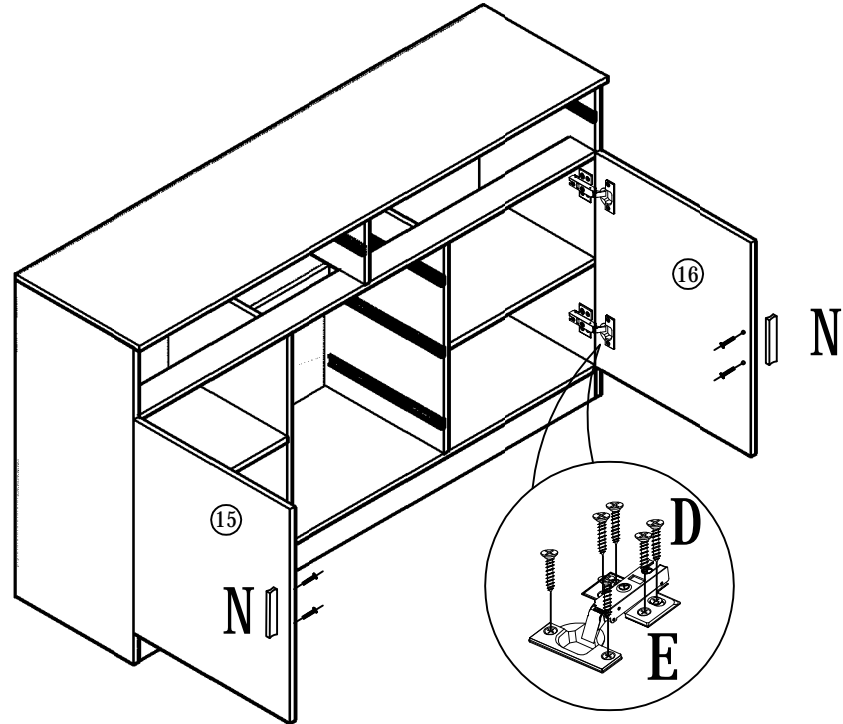

### Hinge Adjustment

If the doors do not appear square or aligned, loosen or tighten the appropriate screws on each case hinge as illustrated.

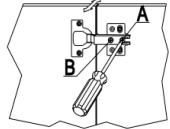

1)Side to side adjustment:  
Loosen screw A, adjust gap with screw B and re-tighten screw A.

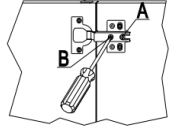

2)Depth adjustment:  
Loosen screw A, push hinge arm forwards or backwards, re-tighten screw A and screw B with a 1/4 turn clockwise.

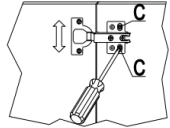

3) Height adjustment:  
Loosen screw C, adjust door height and re-tighten screw C.

D\*24 E\*4 N\*2

19

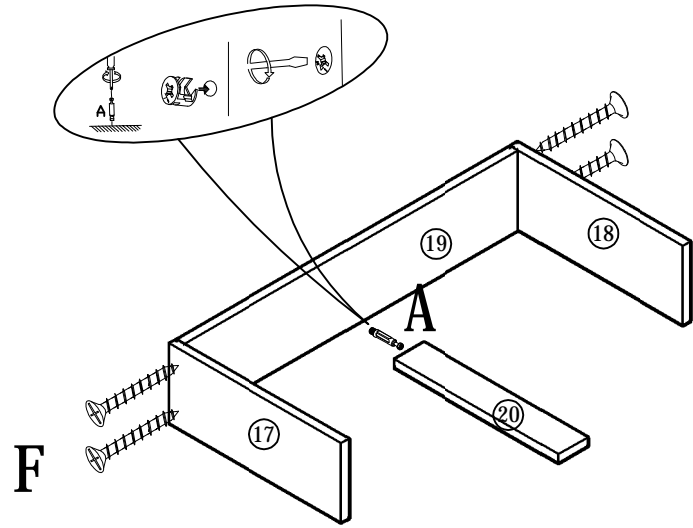

X2

A\*1 F\*4

20

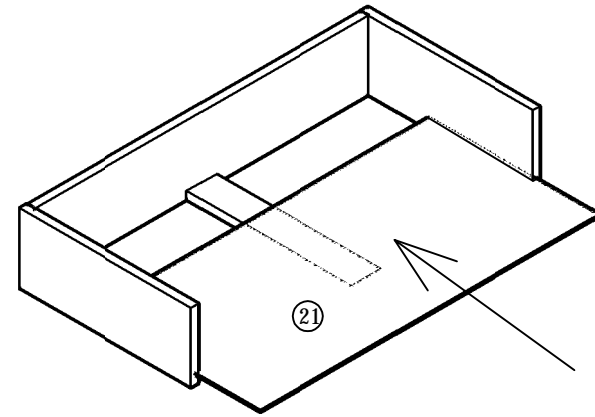

X2

21

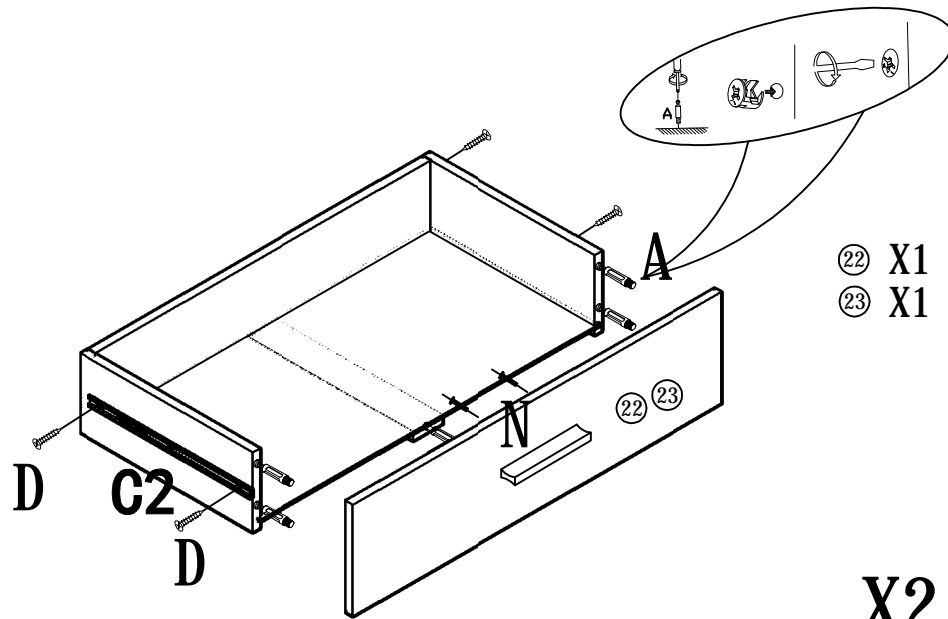

22 X1  
23 X1

X2

A\*5 C2\*2 D\*4 N\*1

22

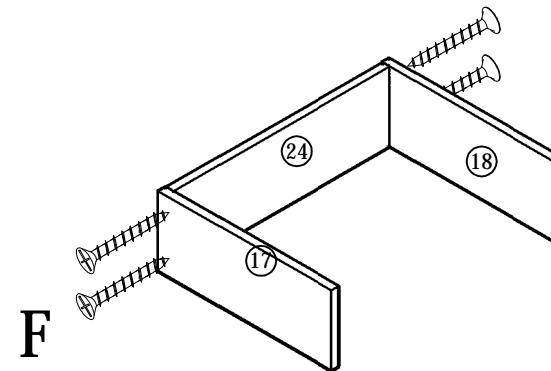

X3

F\*4

23

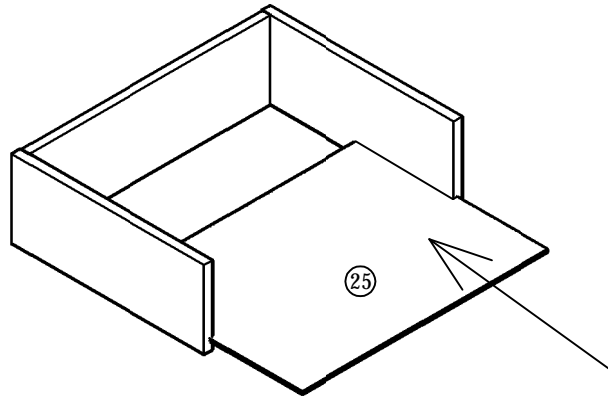

X3

24

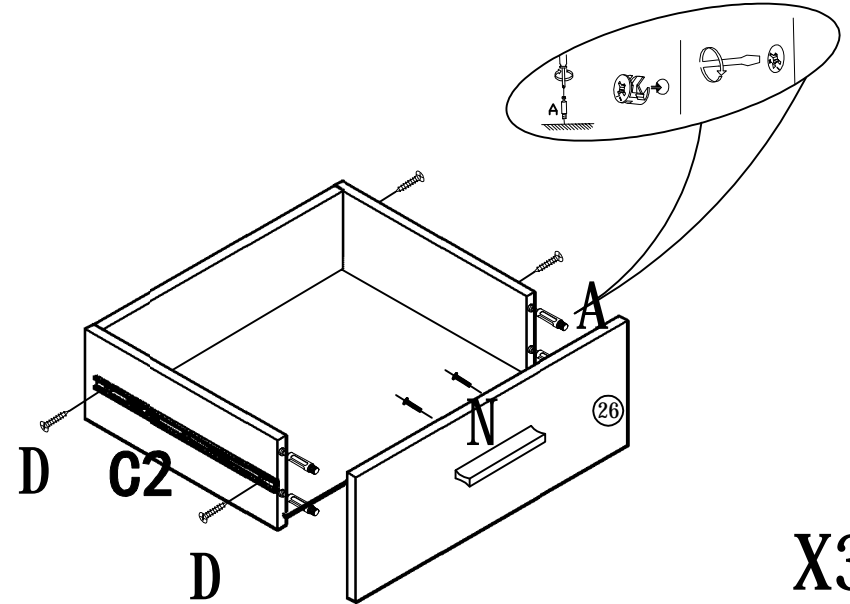

X3

A\*4 C2\*2 D\*4 N\*1

25

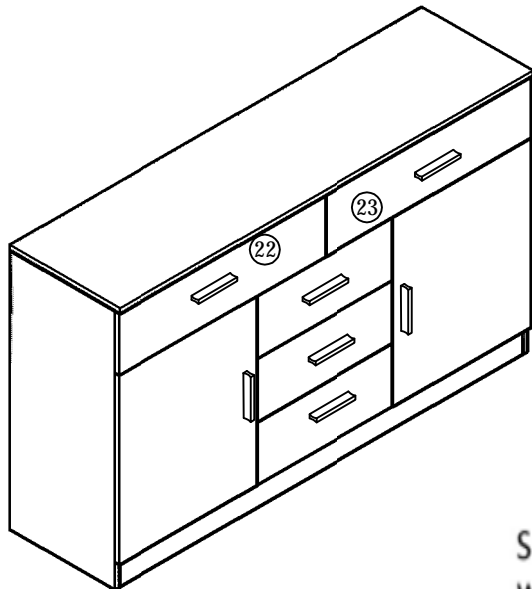

Next, slide in runner C2 (affixed to the drawer) as indicated in the diagram.

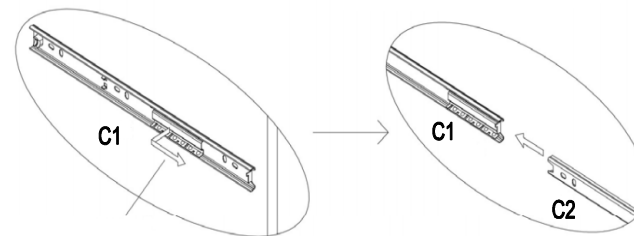

Slide the catch on runner C1 (affixed on cabinet) forward.

Slide in completed drawer with the steps outlined below.