



Intelligent Electric Rice Cooker

Instruction Manual

MB-HS5066W1

Please read the manual carefully before using this appliance and keep them for future reference.

Safety warning

- This appliance is not intended for use by persons (including children) with reduced physical, sensory or mental capabilities, or lack of experience and knowledge, unless they have been given supervision or instruction concerning use of the appliance by a person responsible for their safety.
- Children should be supervised to ensure that they do not play with the appliance.
- This appliance is intended to be used in household and similar applications such as:
 - Staff kitchen areas in shops, office and other working environments;
 - farm houses;
 - by clients in hotels, motels and other residential type environments;
 - bed and breakfast type environments;
- Please turn off and unplug the appliance before cleaning, maintenance or relocation and whenever it is not in use.
- The heating element surface is subject to residual heat after use, do not touch.
- Warning: Avoid spillage on the connector.
- Warning: Misuse may cause potential injury.
- Don't immerse the appliance in water or drench with water.

Safety warning

- The appliance is for household use only.
- If the supply cord is damaged, it must be replaced by a special cord or assembly available from the manufacture or its service agent.

⚡ Reminder

Basic safety precautions should always be followed to ensure secure use and avoid injury and/or property loss to user and others.

⚠ Note

Conditions unconsidered:

The appliance is used by unsupervised children or the disabled.
The appliance is played with by children.

🚫 Represents [FORBIDDEN] content



Prohibit the use of inferior plugs



Prohibit wet hands from touching



Prohibit combustible products



Prohibit children from operating

- Keep the appliance away from combustibles. During operation, stay away from curtains, drapes, curtain or in similar articles to avoid the risk of fire.
- Do not use the appliance for food that may cause vent clogging: food in sheets(e.g.laver and Chinese cabbage), food in bands (e.g.

Safety warning

kelp), food in pieces(e.g.corn dregs), to avoid accident and damage to the appliance.

- During operation, do not place your hands or face close to the steam vent to avoid burns.
- During operation, do not cover the steam vent with cloth or other articles to avoid accident and damage to the appliance.
- Do not reform the appliance: except for maintenance technicians, persons are not allowed to disassemble or repair the appliance to avoid the risk of fire, electric shock and injury to persons.
- Do not use the appliance on any voltage except for 220 - 240 AC to avoid the risk of fire and electric shock. In case of power wire damage, do not use the appliance.

! Represents [MANDATORY] contents

- Independently use grounding socket with rated current of above 13 A. When used with others electrical appliances, the socket will go wrong and lead to dangers such as fire disaster.

Safety warning

- If the power line is too short, user should use an extension socket for connection. Please do not use poor-quality socket. The power consumption of the appliances must not exceed the maximum load of the extension socket.
- Clean the dust and water on both ends of the power line and the socket of the appliance to avoid the risk of fire, electric shock and short circuit.
- When maintenance or parts replacement is necessary, please deliver the product to the authorized professional service centre for maintenance of Midea. to avoid hidden dangers caused by improper maintenance or improper selection of accessories.
- The plug should be thoroughly inserted into the socket to avoid the risk of fire, electric shock and short circuit.
- In case of supply cord damage, the cord should be replaced with a special cord or specialized component purchased from the Manufacturer or the Maintenance Department.

Safety warning

Note: Improper repair or short-circuiting without permission of some important accessories including fuse may lead to protection failure of the appliance and cause overheating or fire.

⚠ Represents [ATTENTION] Matters that may cause minor injuries or property loss

- The appliance can only use the original cooking pot to avoid overheating and anomaly.
- Do not drop the cooking pot to avoid deformation.
- Do not impact the cooking pot with hard materials to avoid deformation.
- When operation is being performed or just finished, do not directly touch the inner cooking pot to avoid burns.

Safety warning

- Before operation, wipe dry the water outside the cooking pot to avoid malfunction.
- Before operation, clean the foreign materials including water drops and rice to avoid overheating and short circuit.

Safety warning

💡 Represents [GENTLE REMINDER] content

- Any discrepancy between the picture and the product is subject to the real object.
- Before operation, check whether the cooking pot and steam valve are in place to avoid accident.
- During use, it is normal that the appliance slightly ticks or fizzes. Please do not panic.
- Do not use the appliance immediately after the first cooking, press the “Cancel” button and wait above 15 minutes for the heating plate to cool down.
- Do not boil rice with hot water to avoid affecting the judgement of the temperature control and worsening the result.
- Please regularly clean the steam valve.
- Please regularly clean the countertop on which the appliance is placed.
- The altitude scope for the appliance to properly function is 0 ~2000 m.
- When maintenance or parts replacement is necessary, please deliver the product to the authorized service centre for maintenance of Midea to obtain professional quality service. Please keep the manual for future reference. Thank you.

Product overview

Parts and Features

Note

All pictures in this manual are subject to material objects, and are only used for function display reference.

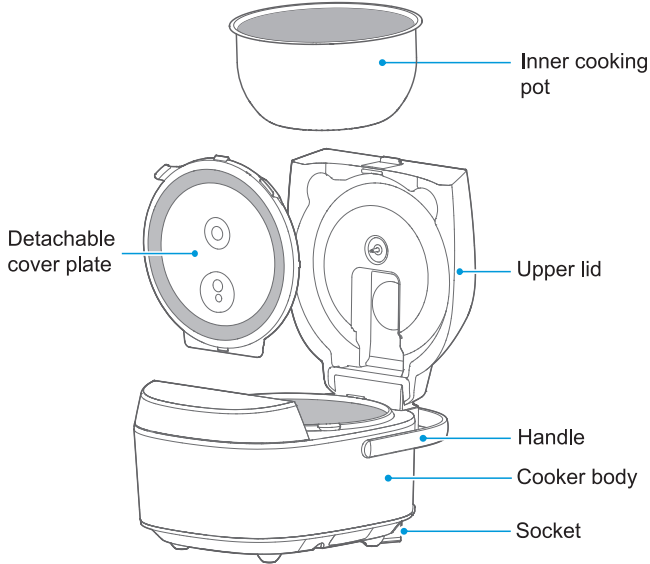

Accessories list



Control panel

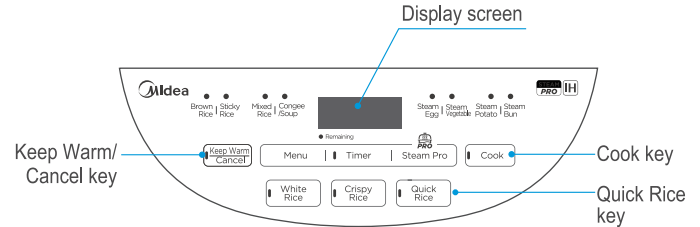

Press "Menu" key to select "Brown Rice, Sticky Rice, Mixed Rice, Congee/Soup".

Press the "Steam Pro" key to select "Steam Egg, Steam Vegetable, Steam Potato, Steam Bun".

Instructions for use

Rice-water ratio

1 Rice measuring method

1 Measuring appropriate volume of rice can cook 2 bowls of steamed rice, and the diameter of the bowl is about 11.5 cm



Instructions for use

Rice-water ratio

2 Put in the rice and water

Take boiling 3 cups of rice as an example, put the washed rice into the inner pot and add water to the corresponding scale line 3.



Volume of water added

Quick start guide (For specific functions, please refer to the physical panel for selective reference)

Rice

1 Cooking preparation

Put the washed rice into the inner pot, inject the water according to the rice-water ratio, then put the inner pot into the pot body, and close the upper cover of the rice pot until the "click" sound is heard.

Note: The amount of water can be increased or decreased according to personal preference.

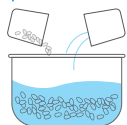

2 Connect the power cord

Push in the plug hard to make sure it is inserted to the bottom. Insert the power plug.

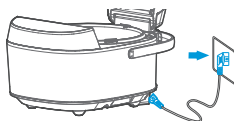

Quick start guide (For specific functions, please refer to the physical panel for selective reference)

3 Choosing function

Press the "Menu" key to select a function (e.g. "Brown Rice").



4 Start cooking

Press the "Cook" key to start the cooking state.



5 Cooking state

After cooking starts, the indication lights will be on, followed by a countdown to cooking time.



6 Cooking completed

After cooking, the heat preservation state starts. If the preservation function is not needed, press the "Keep Warm/Cancel" key to exit the heat preservation standby.



Note:

1. Press "White Rice, Crispy Rice, Quick Rice" shortcut key to enter the cooking state;
2. After cooking, it will automatically trigger the heat preservation function;
3. During the preservation process, the product will be heated to maintain the rice in a state suitable for eating;
4. The product can achieve 24-hours water keeping function;
5. In order to maintain the food taste and appearance, the heat preservation time is suggested within 5 hours;
6. Smart countdown: The rice function has a full countdown display, the cooking time for the amount of small and medium-sized rice is selected by default.

Instructions for use

Functional description (For specific functions, please refer to the physical panel for selective reference)

Timer (take cooking rice as an example)

- 1 Add rice and water (refer to rice-water ratio)

Note: The amount of water can be increased or decreased according to personal preference.

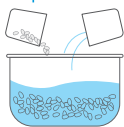

- 3 Pre-set timer setting
Press the "Timer" key, it is flashing, and then press the "Timer" key to adjust the required time. (If the preset time is 8 hours)

Note: Display status refers to actual product.



Note:

1. The preset time is the time to finish cooking.
2. After selecting the preset function, 10 minutes will be added for each time when you press the preset key, and the long press will continuously add 10 minutes;
3. The pre-set time is suggested not for more than 12 hours, otherwise the off-flavor Possible may occur.

- 2 Choosing function
Press the "Menu" or "Steam Pro" key to select a function (e.g. "Brown Rice").



- 4 Start cooking
Press the "Cook" key to preset the cooking state.



Brown Rice

- 1 Will wash clean within meters into the pot, add water to the corresponding water level.
- 2 Close the cover, press the "Menu" key, select "Brown Rice", and then press the "Cook" key to start cooking.

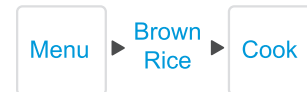

- 3 When cooking completed, open the lid to stir the cooked mixture evenly and ventilate the vapour.



Sticky Rice

- 1 Put sticky rice that is washed clean into the inner pot, with the proposed rice-water ratio of 1:1.1
Add water, and adjust water amount according to personal preferences.
- 2 Press the "Menu" button to select "Sticky Rice" function, then press the "Cook" button.



Note: Rice-water proportion: a cup of rice is about 150g, so the suitable water amount should be $150\text{ g} \times 1.1 = 165\text{ g}$, which can be appropriately adjusted according to personal preferences. When cooking sticky rice, the minimum rice amount is 1 cup, and the maximum amount is 6 cups.

Instructions for use

Functional description (For specific functions, please refer to the physical panel for selective reference)

Mixed Rice

- 1 Soak cereals in hot water for 2-3 hours, put them into an inner pot together with washed rice, and add water to the corresponding water level line.
- 2 Close the cover, press the "Menu" key, select "Mixed Rice", and then press the "Cook" key to start cooking.

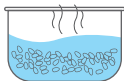

- 3 When cooking completed, open the lid to stir the cooked mixture evenly and ventilate the vapour.



Congee

- 1 Put the washed rice into the inner pot, refer to the rice-water ratio and inject the water according to the congee and water level line, or increase or decrease the water quantity according to personal preference.
- 2 Close the cover, press the "Menu" key, select "Congee/Soup", and then press the "Cook" key to start cooking.



- Note: 1. No injected water can be beyond the highest scale line.
2. For example, the rice-water ratio for bean or cereal congee can be adjusted according to the actual situation.

Soup

- 1 Prepare soup ingredients (such as pig bone, corn, carrots), wash all ingredients and cut into small pieces, then put them into the inner pot, and add water no more than maximum water line.
- 2 Close the cover, press the "Menu" key to select "Congee/Soup", and then press the "Cook" key. After cooking, you can eat.



Steam Pro

- 1 Add water to the "Steam" scale in the inner pot, put the food on the steamer or steaming rack that will be put into the inner pot.
- 2 Close the cover of the rice pot, press the "Steam Pro" key, select "Steam Egg, Steam Vegetable, Steam Potato, Steam Bun", and press the "Cook" key to wait for the cooking to be completed.



Note: For food that is difficult to cook, it is recommended to cook it again; For easy-to-cook food, the food can be taken out in advance after cooking for an appropriate time according to personal taste preferences.

Care and cleaning

Note: Please make sure the appliance is unplugged before cleaning!

1 Disassemble the lid plate for cleaning

- At the same time, pull the position "a" of "ears" on both sides of the cover plate to remove the plate.
- Rinse the whole cover plate with water and dry it.

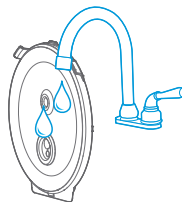
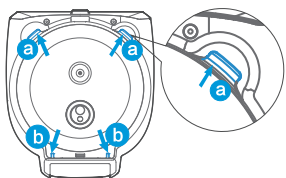

- Insert the cover plate at the concave position "b", push it into the upper cover, press it near the button "a", and hear "click" sound, and then the installation is completed.

2 Steam valve cleaning

Turn the buckle in direction "a", remove the steam valve cap in direction "b", and clean the steam valve cap and steam valve seat.

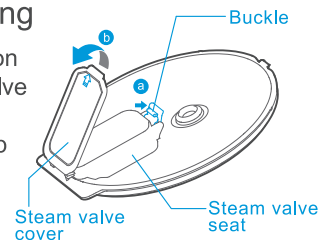

- Note: 1. This steam valve is located at the back of the detachable cover plate, and the steam valve is only disassembled and assembled at the above position. Do not forcefully disassemble and assemble other parts;
2. Before closing the steam valve cap, please install the silica gel sealing ring.

3 Cleaning the cooker body

- It is necessary to clean water, rice, sundries and others on the coil; The casing cover has water storage function. Please keep it clean.
- Clean and dry the bottom of inner pot.

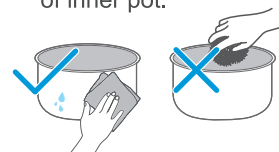

Service guide

Technical data of the product

Product Model	Voltage Frequency	Rated Power (W)	Rice Amount	Heating Method	Product Dimensions Length X Width X Height (mm)	Weight (kg)
MB-HS5066W1	220-240V~50Hz	1300	1.8L	Electromagnetic heating	412x291x262	5.8

Operation Manual

White Rice, Crispy Rice, Quick Rice, Brown Rice, Mixed Rice

Specification	Maximum rice amount	Minimum rice amount
MB-HS5066W1	10 cups	1 cup

Congee

Specification	Maximum rice amount	Minimum rice amount
MB-HS5066W1	3 cups	1 cup

Sticky Rice

Specification	Maximum rice amount	Minimum rice amount
MB-HS5066W1	6 cups	1 cup

Water may be added during steaming process in according to the actual situation. The amount shall be moderate so that the water doesn't flow over the steamer or steaming rack when water is boiled. The amount cannot be too little also, otherwise there might be empty burning situation in the pot.

Note 2: For the water level mark of maximum and minimum rice quantity, please refer to the water level marks in the inner pot. The above parameters are only for reference.

Repair Service

Anomaly self-checking

Display the cause of the abnormality Please contact your local dealer or service network for repair or installation.

Indicator state	Abnormal display	Possible Reason	Solutions
Light on	8 88	Main thermistor (bottom sensor) open circuit	Pull out and re-connect the power cord, the display still shows same message, please send the cooker to your local after-sales service centre for maintenance.
Light on	2 82	Main thermistor (bottom sensor) short circuit	Pull out and re-connect the power cord, the display still shows same message, please send the cooker to your local after-sales service centre for maintenance.
Light on	3 83	IGBT sensor open circuit	Pull out and re-connect the power cord, the display still shows same message, please send the cooker to your local after-sales service centre for maintenance.
Light on	4 84	IGBT sensor short circuit	Pull out and re-connect the power cord, the display still shows same message, please send the cooker to your local after-sales service centre for maintenance.
Light on	5 85	Top lid sensor (handle thermistor) open circuit	Pull out and re-connect the power cord, the display still shows same message, please send the cooker to your local after-sales service centre for maintenance.
Light on	6 86	Top lid sensor (handle thermistor) short circuit	Pull out and re-connect the power cord, the display still shows same message, please send the cooker to your local after-sales service centre for maintenance.
Light on	0 80	Abnormal temperature system error	Pull out and re-connect the power cord, the display still shows same message, please send the cooker to your local after-sales service centre for maintenance.
Light on	8 88	Fan stalled (motor abnormality)	Pull out and re-connect the power cord, the display still shows same message, please send the cooker to your local after-sales service centre for maintenance.
Light on	8 80	Communication error	Pull out and re-connect the power cord, the display still shows same message, please send the cooker to your local after-sales service centre for maintenance.
Flash	8 80	Communication error	Pull out and re-connect the power cord, the display still shows same message, please send the cooker to your local after-sales service centre for maintenance.
Light on	88	Main thermistor (bottom sensor) overheat (high temperature) protection	User checks abnormally for the main thermistor (bottom sensor). The user adjusts the sensor and re-connect the power supply, if the protection message disappears then the cooker can be used normally.
Light on	8 82	IGBT sensor detects overheat (high temperature) protection	Users checks the pot for dry burning, after cleaning and re-connect the power supply, if the protection message disappears then the cooker can be used normally.
Light on	88	Dry burning protection	1. When dry burning detected, the protection message appears on the display screen, All cooking process stops. 2. Users checks the pot for dry burning, after cleaning and re-connect the power supply, if the protection message disappears then the cooker can be used normally.
Light on	0 84	No pot protection	User checks for proper placement of the inner pot, after adjustment and re-connect the power supply, if the protection message disappears then the cooker can be used normally.
Flash	8	Anti-overflow detection circuit failure	Clean the movable cover and anti-overflow detector, press (Cancel) button to cancel the warning message, if the warning message still appears on the display, please send the cooker to your local after-sales service for maintenance.
Power-on display, auto-center timer system and starts flashing from 12:00	82 00	Battery power protection	1. Connect the power supply, system detects low battery voltage level, the clock automatically restarts from 12:00, User cannot use the pre-set timer function, but normal cooking functions still available. 2. After connects the power supply, user may reset the clock and use the pre-set timer function, However, we recommend all uses to bring the cooker to your local after-sales service for battery replacement.

