

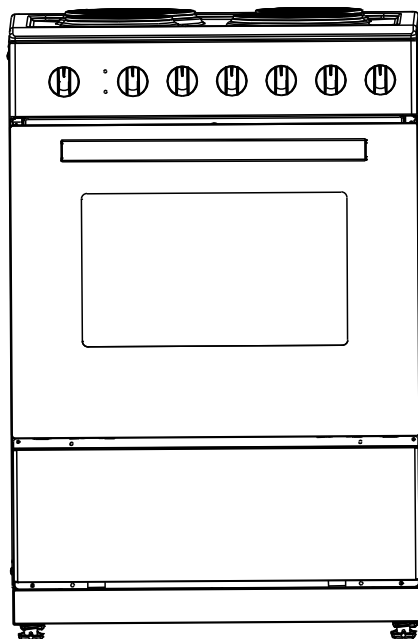

Free Standing Electric Cooker

Instructions for installation and use

24DME4H109



KEEP THESE INSTRUCTIONS IN A SAFE PLACE

Product picture only for reference

Thank you for choosing us! Please read all instructions before using this appliance. This book contains valuable information about operation, care and service. Keep it in a safe place for future reference. Should the appliance be sold or transferred to another owner, or should you move house and leave the appliance, always ensure that the book is supplied with the appliance so that the new owner can be acquainted with the functioning of the appliance and relevant warnings.

Important Safety Warning

THESE WARNINGS ARE PROVIDED IN THE INTEREST OF SAFETY, PLEASE READ THEM CAREFULLY BEFORE INSTALLING OR USING THE APPLIANCE

To maintain the EFFICIENCY and SAFETY of this appliance, we recommend:

- Call the Service Centers authorized by the store where you buy the cooker.
- Always use original Spare Parts

1. This appliance is intended for non-professional use within the home.

2. Before using the appliance, read the instructions in this owner's manual carefully

since you should find all the instruction you require to ensure safe installation, use and maintenance. Always keep this owner's manual close to hand since you may need to refer to it in the future.

3. After removing the packaging, check that the appliance is not damaged. If you have any doubt, do not use the appliance, contact your nearest Service Centre of the store where you buy the appliance. Never leave the packaging components (plastic bags, foamed polystyrene, nails, etc.) within the reach of children since they are a source of potential danger.

4. The appliance must be installed only by a qualified person in compliance with the instructions provided. The manufacturer declines all responsibility for improper installation which may harm persons and animals and damage property.

5. This appliance designed to be used by children aged above 8 years. Person with reduced physical, sensory or mental capabilities or lack of experience and instructed concerning use of the appliances in a safe way and understand the hazards

involved, when using the appliance.

6. The electrical safety of this appliance can only be guaranteed if the cooker is correctly and efficiently earthed, in compliance with current regulations on electrical safety. Always ensure that the earthing is efficient; if you have any doubts call in a qualified electrician to check the system. The manufacturer declines all responsibility for damage resulting from a system which has not been earthed.

7. Check that the electrical capacity of the system and sockets will support the maximum power of the hob, as indicated on the rating label. If you have any doubts, call in a qualified technician.

8. When the cooker is first used an odour may be emitted, this will cease after a period of use. When first using the cooker, ensure that the room is well ventilated (e.g. open a window or use an extractor fan) and that persons who may be sensitive to the odour avoid any fumes. It is suggested that any pets be removed from the room until the smell has ceased. This odour is due to temporary finish on oven liners and elements and also any moisture absorbed by the insulation.

9. Ensure that the appliance is switched off before maintenance, by switching off the main switches and turning all knobs to “OFF” position.

10. The openings and slots used for ventilation and dispersion of heat on the rear and below the control panel must never be covered.

11. The user must not replace the supply cable of this appliance. Always call an after-sales servicing centre authorized by the seller in the case of cable damage or replacement.

12. This appliance must be used for the purpose for which it was expressly designed. Any other use is considered to be improper and consequently dangerous. The manufacturer declines all responsibility for damage resulting from improper and irresponsible use.

13. A number of fundamental rules must be followed when using electrical appliances. The following are of particular importance:

- do not touch the appliance when your hands or feet are wet
- Do not use the appliance barefooted
- Never allow the Mains Cable to be stretched, pulled or damaged if the Cooker is moved for cleaning etc. Do not use the cooker if the

Mains Cable is damaged, consult a qualified electrician.

do not allow the cooker to be used unsupervised by children or persons unfamiliar with it .

14. Always switch off the electrical supply to the cooker and allow it to cool down before carrying out any cleaning operations etc.

15. Danger of fire: do not store items on the cooker surfaces.

16. To avoid accidental spillage do not use cookware with uneven or deformed bottoms on the burners or on the electric plates.

17. Special care should be taken when using chip pans etc. in order to avoid splashing or spillage of hot oil. They should not be used unattended since overheated oil may boil over and could also ignite.

18. Parts of this appliance, cooking surfaces, retain heat for considerable periods after switching off. Care should, therefore, be taken when touching these areas before they have completely cooled down.

19. Never use flammable liquids such as alcohol or gasoline, etc. near the appliance when it is in use.

20. When using small electrical appliances near the hob, keep the supply cord away from the hot parts.

21. Make sure the knobs are in its "OFF" position when the appliance is not in use. Also make all potentially dangerous parts of the appliance, safe, above all for children who could play with the appliance.

22. When the appliance is in use the , heating elements and some parts of the oven door become extremely hot. Make sure you don't touch them and keep children well away .

23. If you use the power cable for single phase, the minimum cross-sectional area is 10mm^2 . For there phases, the minimum cross-sectional area is 2.5mm^2 .

24. The appliance that you have bought may be slightly different from the one illustrated in this manual. Please refer to the information related to the model you have.

25. Do not use harsh abrasive cleaner or sharp metal scrapers to clean the oven door glass since they can scratch the surface, which may result in shattering of the glass.

26. Any spillage should be removed from the lid before opening and the hob surface should be allowde to cool before closing the lid.

27. You must colse the door when grill.

Installation

The following instructions should be read by a qualified technician to ensure that the appliance is installed, regulated and technically serviced correctly in compliance with current regulations.

Important: remember to disconnect the appliance from electricity by turning off the mains switch before regulating the appliance or carrying out any maintenance work.

Positioning

Important : The hob should never be installed in proximity of a door access. People opening and closing the door could come into contact with pots or pans cooking on the hob. This unit may be installed and used only in permanently ventilated rooms:

Unpacking

- Be careful when unpacking and installing the appliance. Sharp edges might cause accidents.
- The oven is heavy and care must be taken when moving it. Ensure that all packing, both inside and outside the cooker, has been removed before the oven is used.
- Unpack the oven from the carton, check and make sure it has not been damaged in any way. If you have any doubts, do not use it, contact the service center or where you buy the oven.

Installation

The cooker is designed to fit between kitchen cabinets. The space either side need only be sufficient to allow withdrawal of the cooker for servicing. It can be used with cabinet one side or both as well as in a corner setting. It can also be used free-standing.

The appliances can be installed next to furniture units which are no taller than the top of the cooker hobs. If the cooker is placed touching walls or sides of neighboring cabinets, these must be capable of withstanding a temperature rise of 50 °C above room temperature. For a correct installation of the cooker the following precautions must be followed:

- The cooker may be located in a kitchen, a diner or bed sitting room, but not in a bathroom or shower room.
- Kitchen cabinets installed next to the cooker that are taller than the top of the cooker hobs must be situated at least 20cm from the edge of the hobs.
- Hoods must be installed according to the requirements in the installation manual for the hoods themselves and in any case at a minimum distance of 65cm.
- Place the wall cabinets adjacent to the hood at a minimum height of 42 cm from the hobs as indicated in figure 1.
- The hoods must be installed according to the requirements in the hood handbook.
- Should the cooker be installed beneath a wall cabinet, the latter should be situated at least 70cm away from the hobs as indicated in figure 1.
- The cut-out for the cooker cabinet should have the dimensions indicated in the figure 1.
- The wall in contact with the back of the cooker must be of flameproof material.

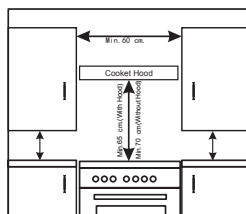

Figure 1

Levelling Your Appliance

Take out the 4 cooker feet from oven cavity, which was packed together with baking rack, and then screw them into the plinth in lower part of cooker. These feet level off the oven when necessary. The height of the cooker can be adjusted by means of adjustable feet in the plinth. Adjust the feet by tilting the cooker from the side. Then install the product into position. It is essential that the cooker is standing level before installation.

Install Anti-tilt Bracket

Warning: In order to prevent tipping of the cooker, the anti-tilt bracket must be installed with cooker. To install Anti-tilt bracket, use screwdriver to mount the anti-tilt bracket (1) with screws (2) to the ground, as shows in Figure 3.

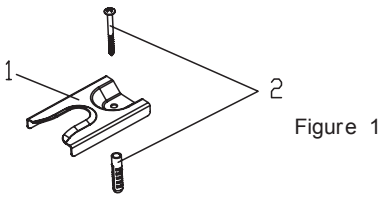

Figure 2

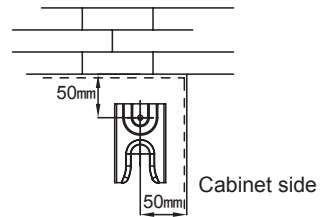

Figure 3

Fitting the safety chain and hook

To prevent the cooker from tipping forward, two lengths of chain **MUST BE** fixed to the back of the cooker, which should be secured to the hooks provided at all times.

The hooks should be secured to the wall at the rear of the cooker. The chains should always be attached to the hooks when the cooker is in position against the wall.

Fix the hooks into the wall immediately behind the cooker on both sides.

Secure the chain to the hook before using or cleaning the oven.

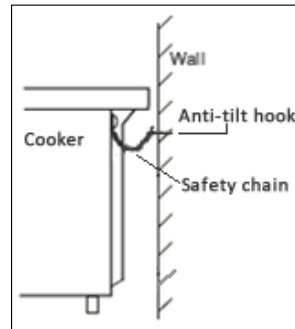
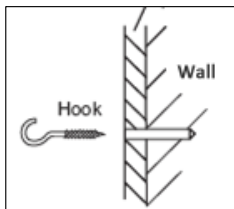

After fixing anti-tilt bracket, push the electric cooker inside cabinet as show in Figure 4. For correct installation, the rear and right foot of cooker would be clipped by the anti-tilt bracket.

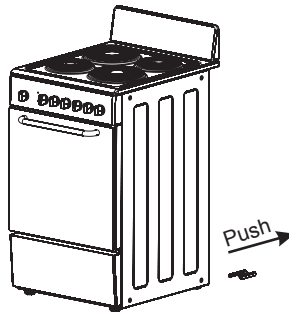

Electrical connection

Power supply voltage and frequency: 220-240V A.C. 50Hz-60Hz.

The electric cooker without a power supply cable. The cooker is designed to operate on an electricity supply which conforms to the electrical data shown on the Rating label. The cooker can be connected to the mains only after removing the back panel of the cooker itself with a screwdriver.

Note: the following installation procedure must be carried out by a qualified electrician. For the installation of the mains cable carry out the following operations:

1. Open the terminal board by inserting a screwdriver into the side tabs of the power code cover. Use the screwdriver as a lever by pushing it down to open the cover as below:

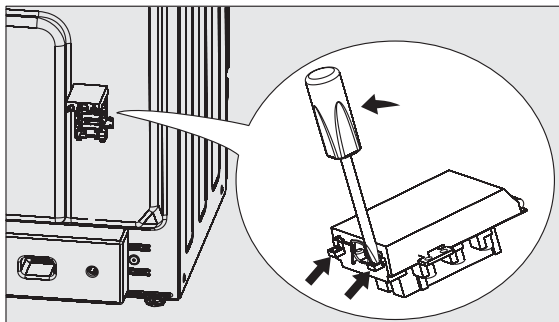

2. Connect the electricity follows the diagram as printed in the surface of power code cover.
 3. Fasten the supply cable in place with the clamp and close the cover of the terminal board.
- Note: The red electricity indicator on control panel will illuminate once connect to electricity.

Safety Information

When used properly your appliance is completely safe but as with any electrical product there are certain precautions that must be observed.

PLEASE READ THE PRECAUTIONS BELOW BEFORE USING YOUR APPLIANCE.

Always

- Turn controls OFF when you have finished cooking and when not in use.
- Stand back when opening an oven door to allow any build up of steam or heat to disperse.
- Use dry good quality oven gloves when removing items from the oven/grill.
- Place pans centrally over the hotplate making sure handles are kept away from the edge of the hob and cannot become heated by other hotplate/pans.
- Take care to avoid heat/steam burns when operating the controls.
- Turn off the electricity supply before cleaning and allow the appliance to cool.
- Make sure the shelves are in the correct position before switching on the oven.
- Take care when removing items from the grill when the lower oven is on as the contents will be hot.
- Keep the appliance clean, as a build up of grease or fat from cooking can cause a fire.
- Follow the basic principles of food handling and hygiene to prevent the possibility of bacterial growth.
- Keep ventilation slots clear of obstructions.
- Refer servicing to a qualified appliance service engineer.
- Take care to avoid touching heating elements inside the oven, as during use the oven becomes hot.

Never

- Never line the interior of the oven with foil as this may cause the appliance to overheat.
- Never leave children unsupervised where a cooking appliance is installed as all surfaces will be hot during and after its use.
- Do not allow children or persons who are not familiar with the appliance to use it, without supervision.
- Never allow anyone to sit or stand on any part of the appliance.
- Never store items above the appliance that children may attempt to reach.
- Never leave anything on the hob surface when unattended and not in use.
- Never remove the oven shelves whilst the oven is hot.
- Never heat up unopened food containers as pressure can build up causing the container to burst.
- Never store chemicals/food stuffs, pressurized container in or on the appliance, or in cabinets immediately above or next to the appliance.
- Never place flammable or plastic items on or near the hob.
- Never fill a deep fat frying pan more than 1/3 full of oil, or use a lid.

DO NOT LEAVE UNATTENDED WHILE COOKING.

- Never use the appliance as a room heater.
- Never use the grill to warm plates.
- Never dry any items on either the hob or oven doors
- Never install the appliance next to curtains or other soft furnishings.
- Never use steam cleaners.

SAFETYADVICE IN CASE OF A CHIP-PANFIRE

In the event of a chip pan fire or any other pan fire.

1. TURN OFF THE COOKER APPLIANCE AT THE WALL SWITCH.
2. COVER THE PAN WITH A FIRE BLANKET OR DAMP CLOTH, this will smother the flames and extinguish the fire.
3. LEAVE THE PAN TO COOL FOR AT LEAST 60 MINUTES BEFORE MOVING IT. Injuries are often caused by picking up a hot pan and rushing outside with it.

NEVER USE A FIRE EXTINGUISHER TO PUT OUT A PAN FIRE as the force of the extinguisher is likely to tip the pan over!

Never use water to extinguish oil or fat fires!

Safety reminding



Caution, possibility of tilting



Anti-tip restraints

WARNING: In order to prevent tipping of the appliance, this stabilising means must be installed. Refer to instructions for installation.

Product Description

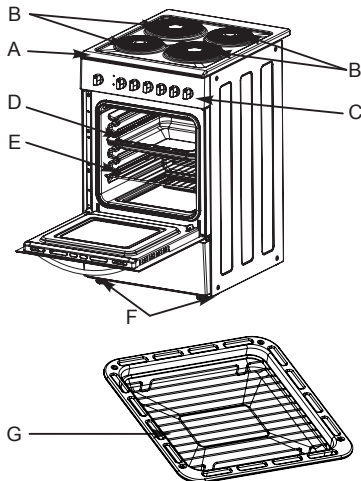

- A. Cooktop
- B. Solid Hotplate
- C. Control Panel
- D. Baking Pan
- E. Baking Rack
- F. Adjustable Feet
- G. Trivet

Operation Instructions

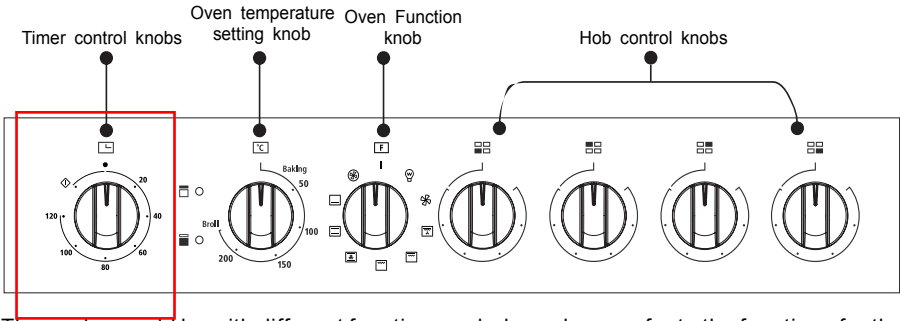

The cooker could be with different functions as below, please refer to the functions for the cooker you buy.

Symbol	Function description
	Oven Lamp: Enables the user to observe the progress of cooking without opening the door. Oven lamp will lighting for all cooking functions, for the cooker with this optional function.
	Defrost: The circulation of air at room temperature enables quicker thawing of frozen food,(without the use of any heat). It's a gentle but quick way to speed up the defrosting time and thawing of ready-made dishes and cream filled produce etc.
	Bottom heat: A concealed element in the bottom of the oven provides a more concentrative heat to the base of food without blowing.
	Conventional cooking: The top and bottom work together to provide convectional cooking.
	Convention with fan: Combination of the fan and both heating element provides more even heat penetration, saving up to 30-40% of energy. Dishes are lightly browned on the outside and still moist on the inside.
	Radiant grilling: The inner grill element switches on and off to maintain temperature.
	Double grilling: The inside radiant element and top element are working.
	Double grilling with fan: The inside radiant element and top element are working with fan.
	Convection: An element around the convection fan provides an additional source of heat for convection style cooking. In convection mode the fan automatically comes on to improve air circulation within the oven and creates an even heat for cooking.

Hobs control:

Note: Always ensure that all controls are in the OFF position, when the appliance is not in use.

Note: Under no circumstances should the hob be used with aluminum foil in contact with the hob surface.

The knobs for the hobs can be rotated in either direction to provide variable heat control. Turn the hobs control knobs anticlockwise from OFF position to increase power, there are 6 positions for different power rating. Turn the control to 6 for fast cooking. To cook more slowly or simmer, turn the control to a lower setting according to the size of the saucepan and the amount of liquid. the two small Hotplates are special for smaller pans, low temperature cooking and simmering.

Do not leave a hotplate switchde on without a pan as this wastes energy and may shorten the life of the hotplate

CONTROL SETTINGS GUIDE

This is provided only recommended guide-setting also depend on the type of pan used and the quality of food.

Knob Position	Type of foods
1	To melt butter, chocolate, etc.
1 or 2	To heat foods gently. To keep small amount of water simmering. To heat sauces, containing egg yolks and butter. To simmer: stews, meat, fish, vegetables, fruit.
3	To heat solid and liquid foods. Keeps water boiling. Thaw frozen vegetables. Make 2-3 egg omelettes.
4 or 5	To cook foods, just above simmering. To maintain "rolling" boil for preserve making.
5 or 6	To seal meat and fry fish
6	Frying potatoes. Bringing water to the boil. Deep fat frying. Dissolve sugar for preserve making.

Safety requirements for deep fat frying

1. Use a deep pan ,large enough to completely cover the appropriate area.
2. Never fill the pan more than one-third full of oil.
3. Never leave oil or fat unattended during the heating or cooking period.
4. Never try to fry too much food at a time, especially frozen food. This only lowers the temperature of the oil or fat too much, resulting in greasy food.
5. Always dry food thoroughly before frying, and lower it slowly into the hot oil or fat. Frozen foods, in particular, will cause frothing and spitting, if added too quickly.
6. Never heat fat, or fry, with a lid on the pan.
7. Keep the outside of the pan clean and free from streaks of oil or fat.

Hotplates General Information Notes

Always	Never
Use good quality flat-based cookware on all electric heat sources.	Use gauze, metal pan diffusers, asbestos mats and stands e.g. Wok stands- they can use overheating.
Always ensure pans have clean, dry bases before use.	Use utensils with skirts or rims e.g. buckets and some kettles.
Ensure pans match size of heating area.	Use badly dented or distorted pans.
Remember good quality pans retain heat well, so generally only a low or medium heat is necessary.	Leave an element switched on when not cooking.
Ensure pan handles are positioned safely and away from heat sources.	Cook food directly on the ceramic glass or hotplates.
Always lift pans, do not drag.	Drag or slide utensils, along the hob surface.
Always use pan lids except when frying.	
Deal with spillages immediately but with care.	

Do Not

Do not cook directly on the hob surface without a cooking utensil, as this will result in damage to the surface of the hob.

Do not use the hob as a worktop surface as damage may occur to the smooth surface of the hob.
Do not drag or slide utensils on the hob surface, as this will cause scratches in the surface of the hob.

Do not allow a cooking utensil to come into contact with the hob surround.

Do not leave any utensils, food or combustible items on the hob when it is not in use.

Do not place aluminum or plastic foil, or plastic containers on the hob.

Do not leave the hotplates or cooking areas switched ON unless they are being used. We recommend not to place large preserving pans or fish kettles across two heating areas.

Do not leave utensils partly covering the heated areas. Always ensure that are placed centrally over the heated areas and have the same diameter as the heating area used.

We recommend not to use a utensil with a base diameter greater than 25cm. Pressure cookers or other large pans should be used on the front cooking areas. Always ensure that saucepan handles are positioned safely.

Choosing Your Utensils

Do not use utensils with rough bases.

Do not use lightweight utensils with thin, distorted or uneven bases.

Do not use lightweight enamelled steel utensils.

Do not use cast iron utensils.

Do not use utensils with recessed, scrolled or ridged bases.

Do not use a utensil which has a base concavity greater than 1mm as this will reduce the performance of the hob.

Do not use a utensil with a convex base.

Do not use glass ceramic utensils.

Oven Control

The oven temperature setting knob can only be rotated clockwise from the OFF position. Turn oven function control knob to select the cooking function, meanwhile turn the timer (for the model with timer) to set the cooking time you want. Then turn oven temperature control clockwise to the required oven temperature. The red oven temperature pilot light will immediately illuminate and will automatically go off when oven temperature reaches the temperature setting.

Cleaning and Maintenance

Before each operation, disconnect the cooker from the electricity. To assure the long life of the cooker, it shall be thoroughly cleaned frequently, keeping in mind that:

1. Wait until the oven has cooled before removing the wire shelves, wash them separately in warm soapy water and dry thoroughly.
2. Wash the interior of the oven with hot soapy water and wipe down with a damp cloth.
3. Leave the door open until the interior has dried, before replacing the wire shelves.
4. Clean the oven after each use, especially after roasting or grilling this will prevent spilt or splattered food debris burning and becoming difficult to remove.
5. Do not use abrasive pads to clean the interior of the oven as this may remove the enamel, which will affect the efficiency of your oven.
6. Do Not use harsh, abrasive cleaners or sharp metal scrapers to clean the oven door glass since they can scratch the surface, which may result shattering of the glass.

Cleaning the outside of the oven

1. You should regularly wipe over the control panel, oven door and oven sides using a soft cloth and mild liquid detergent as spilt liquids may damage the enamel.
2. Wash enameled or chrome plated parts of the oven with warm soapy water or with non-abrasive detergents.
3. Never use abrasive pads to clean enameled, chromed or stainless steel surfaces.
4. When using commercially available stainless steel cleaning products, avoid cleaning any lettering or symbols, as they can become damaged.

Removing the door for easier cleaning

We recommend you have someone to assist you during removal of the door.

1. Open the door completely.
2. The door hinge has a small latch. Lift the latch on both hinges.
3. Lift the door slightly as if closing, and then with both hands supporting the door, pull it away from the oven.
4. To replace the door, hold the door in an open position and insert the latches on both hinges back into place. Open and close the door to make sure that it has been fitted correctly.

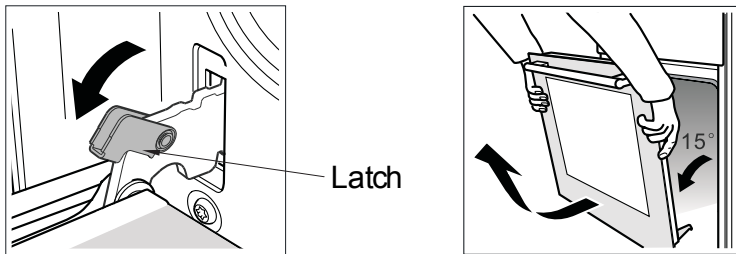

Oven Lamp Replacement

1. Switch off and disconnect the power from the oven. Ensure that the internal parts are cool before touching internal parts.
2. Remove the lamp cover by turning it counter-clockwise (note, it may be stiff), replace the bulb with a new one of the same type.
3. Insert the new bulb, which should be resistant to 300°C. For replacement bulbs contact your local service centre.
4. Re-fit the cover.
5. If in any doubt, consult a qualified electrician for help.

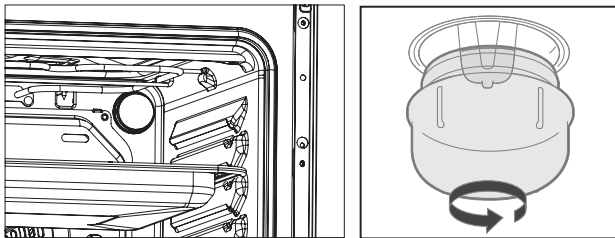

WARNING: To avoid electric shocks—please ensure that the electricity supply to the appliance is switched off and the appliance is fully cold, before removing the lamp lens.

Troubleshooting

Customer service

Before contacting the authorized service center in case of problems while using your cooker, check the problem guide below; there may be nothing wrong with your cooker.

Problem	
Slight odour or small amount of smoke when using the cooker for the first time.	This is normal and should cease after a short period. If using a grill after roasting, then smoke may appear from deposits caused by roasting, this is normal.
Nothing Works	Is the main cooker wall switch turned on? There may be no electricity supply.
Oven does not cook evenly.	Check that the containers being used in the oven allow sufficient air flow around them. Check that the cooker is level.
Hotplates are slow to boil or will not simmer	Check that your pans conform to the recommendations in these instructions.
Marks appearing on hotplates. Can not clean hob / hotplates.	The hob surround can be cleaned with warm water & nonabrasive cleaner
Grill keeps turning on and off.	When the grill control is operated at a setting less than maximum, this is normal regulator, not a fault.
Condensation on the wall at the rear of the cooker.	Steam and/or condensation may appear from the vent at the rear of the appliance when using an oven particularly for foods with a high water content e.g. frozen chips, roast chicken etc. This is normal and any excess should be wiped off.
Steam / Condensation in the oven after use.	Steam is a by-product of cooking any food with high water content. This is normal and could be clean when regular cleaning of cooker. roast chicken etc. This is normal and any excess should be wiped off.

If you have checked these point and still have a problem with your appliance or require spare parts, call your retailer or contact our customer services team.

- model name/num ● date of purchase ● contact Num
- serial Num ● where purchase ● description of fault
- cust Name and address

Technical Characteristics

Top element	950W
Bottom element	1100W
Grill element*	2000W
Convection element*	2000W
Convection fan motor*	33W
Rotisserie motor*	4W
Lamp*	25W
Solid hotplate 145mm(RR, LF)	1000W*2
Solid hotplate 180mm(RF, LR)	1500W*2
Rapid hotplate 145mm*	1500W
Rapid hotplate 180mm*	2000W
Cavity volume	65L

* (only available on certain models)

Voltage and Frequency of Power Supply:
Refers to rating label



This symbol on the product or in the instructions means that your electrical and electronic equipment should be disposed at the end of its life separately from your household waste. There are separate collection systems for recycling in the EU. For more information, please contact the local authority or your retailer where you purchased the product.

