

ASSEMBLY INSTRUCTION

PART LIST:

		
AX1	BX4	CX2

Step 1:

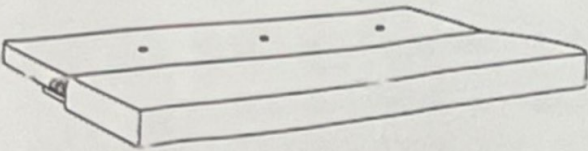
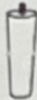
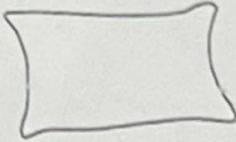
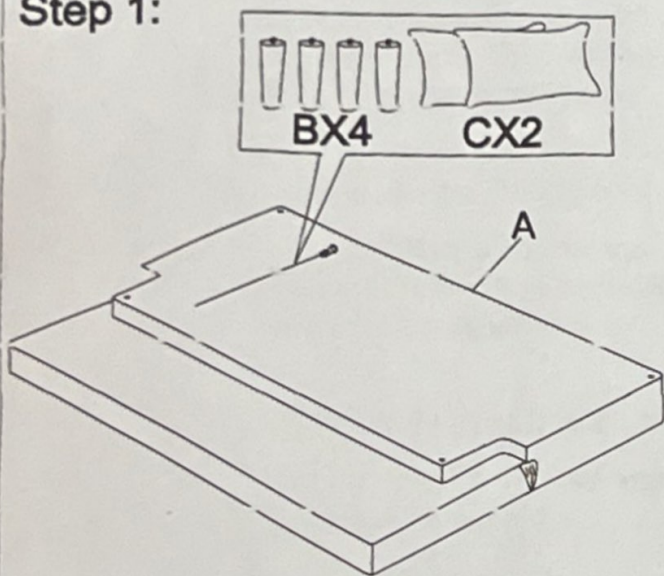

Step 2:

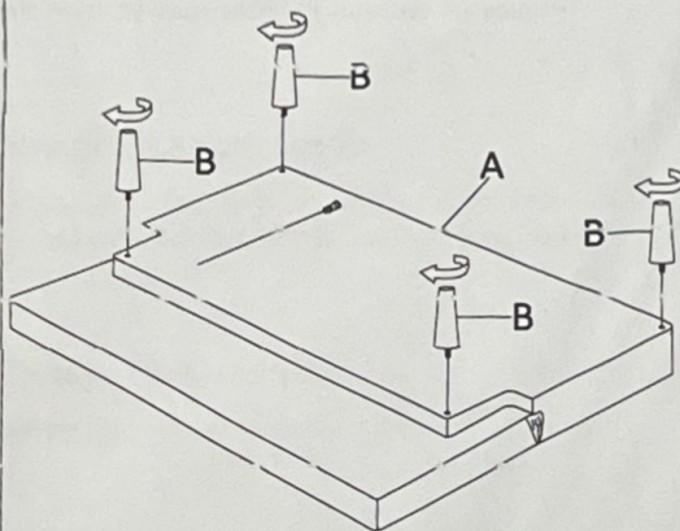

Step 3:

Step 4:

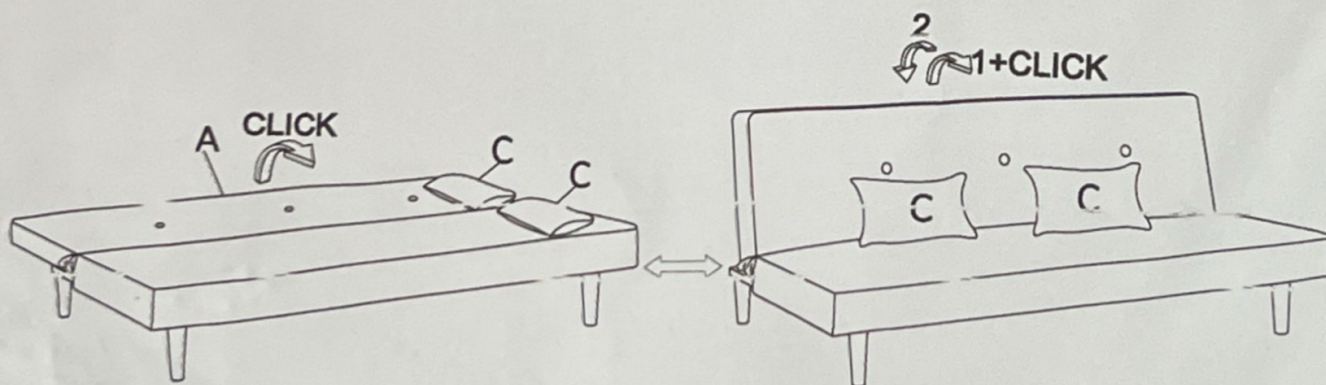

RETURN / DAMAGE CLAIM INSTRUCTIONS

1. **DO NOT** discard of the box / original packaging.

In case a return is required, the item must be returned in original box. Without this your return will not be accepted.

2. Take a photo of the box markings.

A photo of the markings (text) on the box is required in case a part is needed for replacement. This helps our staff identify your product number to ensure you receive the correct parts.

3. Take a photo / Video of Damage (if applicable).

A photo /video of the damage is always required to file a claim and get your replacement or refund processed quickly. Please make sure you have the box even if it is damaged.

4. Send us an email with the images requested.

Email us directly with the attached images, order number (SOXXXX) and a description of your claim.

Auckland / Waikato / BOP Branch: sales@tsbliving.co.nz
Christchurch Branch: customersupport@tsbliving.co.nz
Wellington Branch: wellington@tsbliving.co.nz