

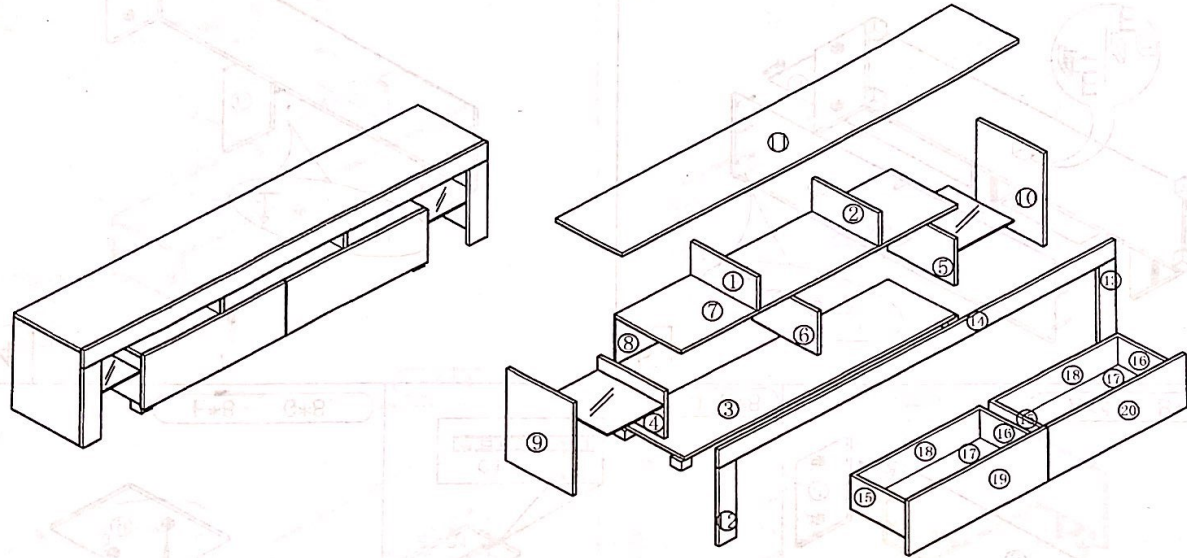





Glanitz Glamorg TV Unit

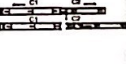

A 48pcs 	B 11pcs 	C 2pcs 	D 8pcs 	E 52pcs 	F 5pcs 	G 8pcs 	H 1pcs 
---	---	--	---	---	--	--	--

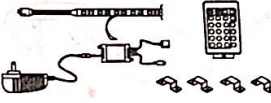
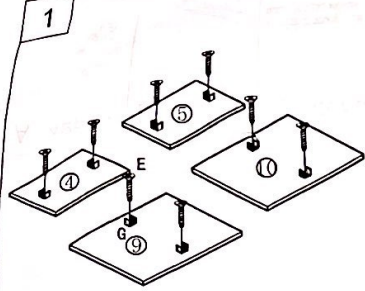

E*8 G*8

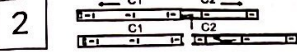

Remove c2 from c1 by sliding it out and pressing on the catch as indicated.

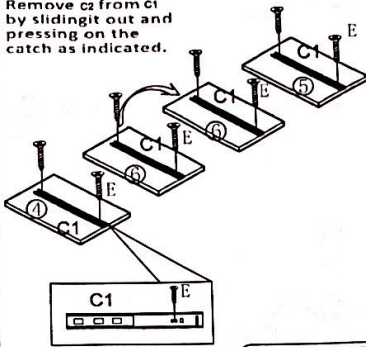

C1*4 E*8

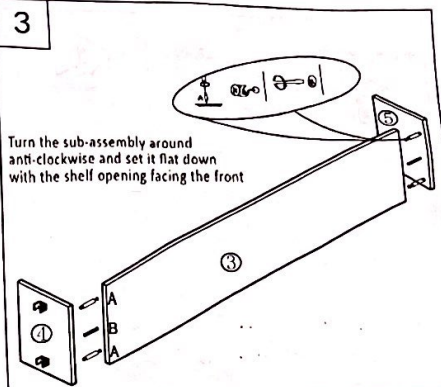

A*4 B*2

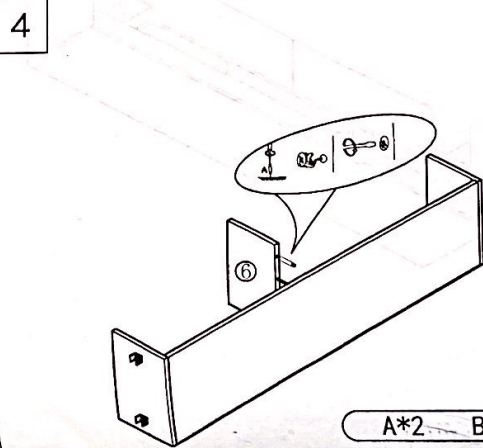

A*2 B*1

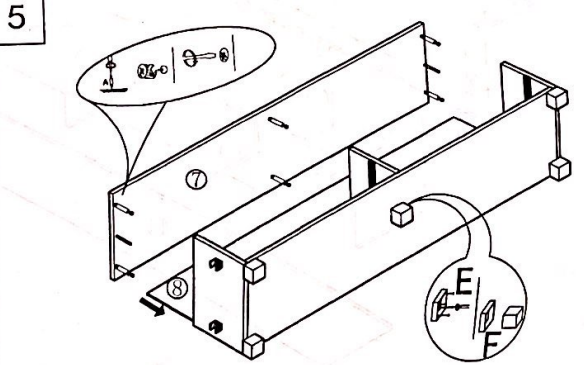

A*6 B*2 E*20 F*5

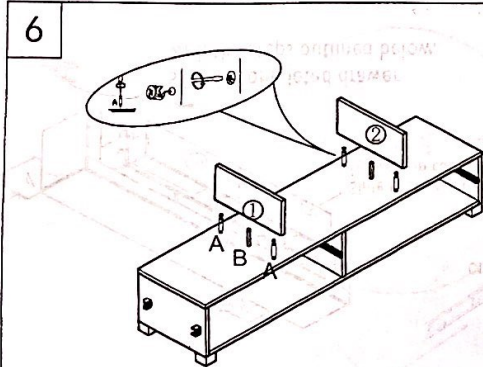

A*4 B*2

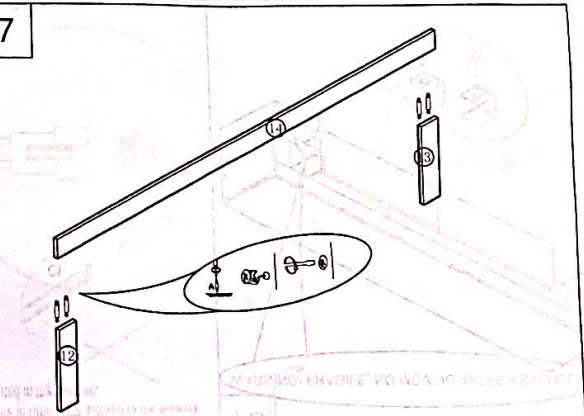

A*4

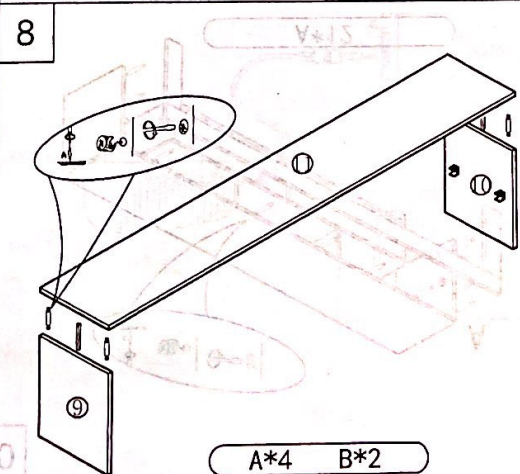

A*4 B*2

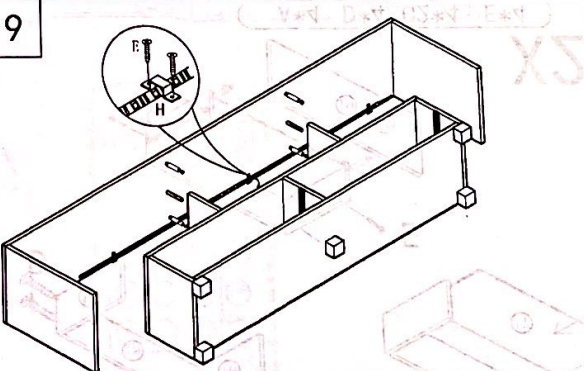

A*4 Bx2 E*8 H*1

10

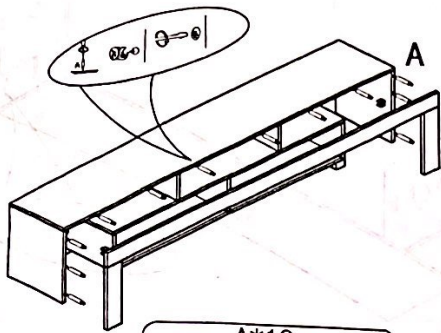

A*12

11

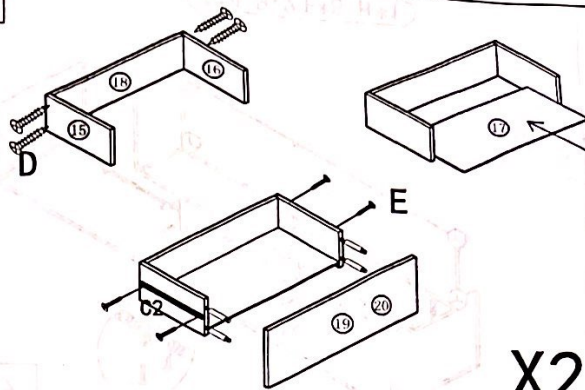

A*4 D*4 C2*4 E*4

X2

12

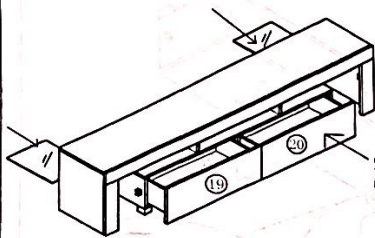

Slide the catch on runner C1 (affixed on cabinet) forward.

Slide in completed drawer with the steps outlined below.

Next, slide in runner C2 (affixed to the drawer) as indicated in the diagram.

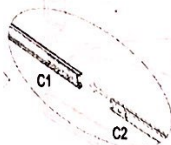
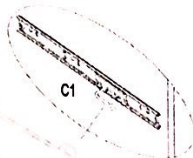

13

WARNING: FRAGILE, NO MOVING AFTER ASSEMBLE!

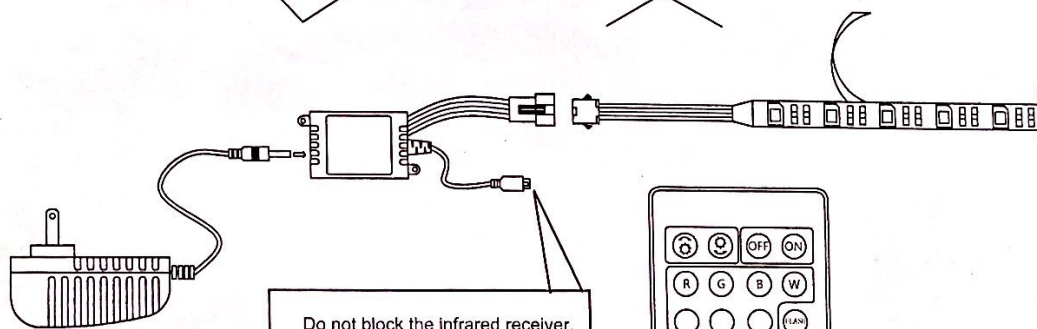
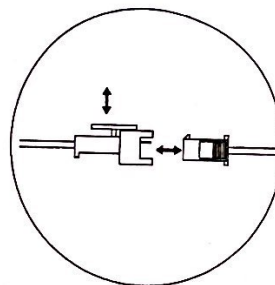
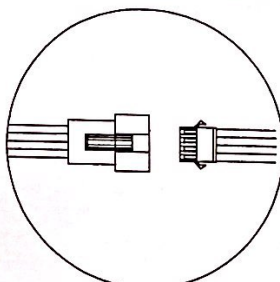
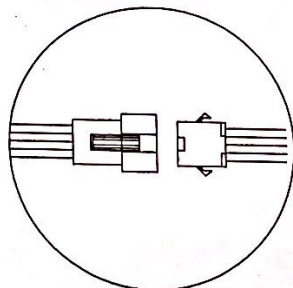
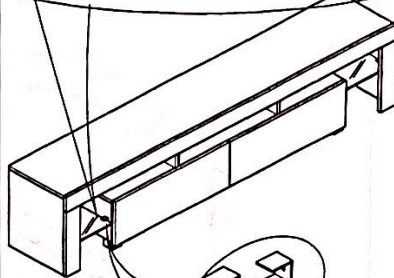

Do not block the infrared receiver, and also align the infrared receiver when operating.

Pull out the plastic sheet before use.