

Choco Queen Bed Frame Black

PARTLIST

① Headboard 1pc

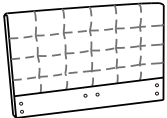

② Footboard 1pc

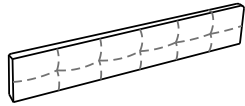

③ Support Leg x 2pcs

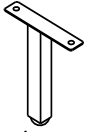

④ Side Rail x 2pcs

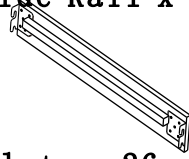

⑤ Centre Support Bar x 1pc

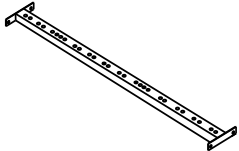

⑥ Slats x 26pcs

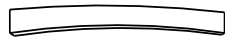

⑦ Double Plastic Cap x 13pcs



⑧ Single Plastic Cap x 26pcs

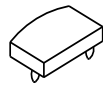

⑨ Leg x 4pcs



HARDWARE LIST

(A) Bolt M8 x 30mm x 16pcs (B) Nut M8 x 13mm x 4pcs

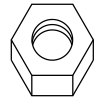
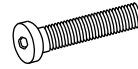

(C) Spring Washer x 8pcs (D) Flat Washer x 8pcs



(E) Allen Key M5 x 1pc (F) Spanner x 1pc

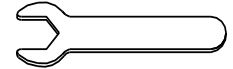

(G) Bolt M8 x 50mm x 4pcs

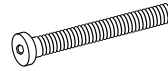

STEP 1

Bolt the bed legs onto the bottom of the head and foot ends using 60mm bolts

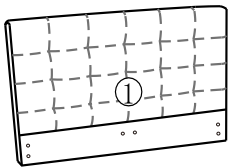

⑨

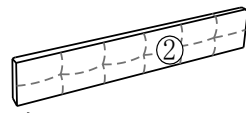
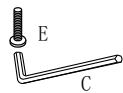

⑨

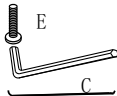

STEP 3

Fixing side rails and centre support bar to headboard and footboard.

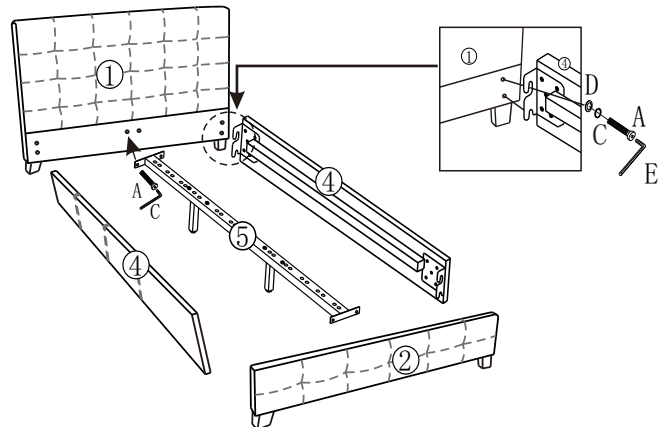

STEP 2

Bolt the centre rail in place using 4*30mm bolts and adjust the centre leg feet down to contact the floor.

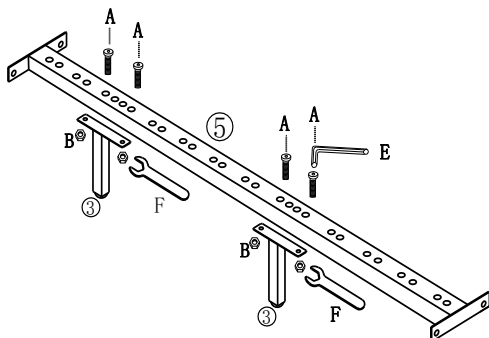

STEP 4

Fixing plastic caps and slats

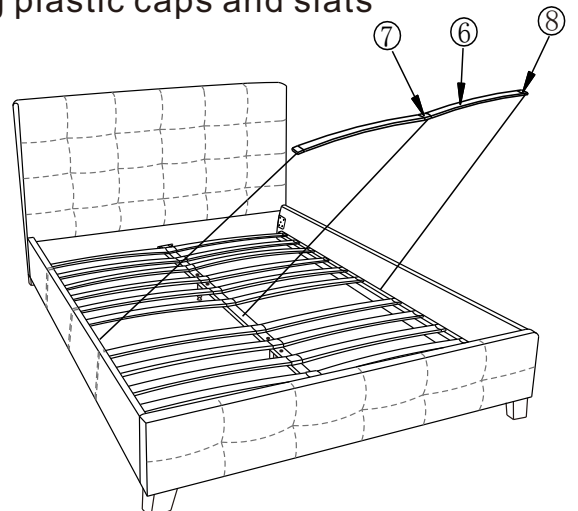

**IMPORTANT: NEVER DRAG THE ASSEMBLED BED.
TO MOVE, ALWAYS LIFT FROM BOTH SIDES.**