

## Troubleshooting Guide

Problem	Possible Cause	Solution
Vehicle does not run	Battery low on power	Recharge battery.
	Thermal fuse has tripped	The fuse will reset automatically in 20 seconds.
	Battery connector or wires are loose	Check that the battery connectors are firmly plugged into each other. If wires are loose around the motor <b>contact your distributor please.</b>
	Battery is dead	Replace battery, <b>contact your distributor please.</b>
	Electrical system is damaged	<b>Contact your distributor please.</b>
	Motor is damaged	<b>Contact your distributor please.</b>
Vehicle does not run very long	Battery is under charged	Check that the battery connectors are firmly plugged into each other when recharging
	Battery is old	Replace battery, <b>contact your distributor please.</b>
Vehicle runs sluggishly	Battery low on power	Recharge battery, <b>contact your distributor please.</b>
	Battery is old	Replace battery, <b>contact your distributor please.</b>
	Vehicle is overload	Reduce weight on vehicle. Maximum user weight is 50 kg.
	Vehicle is being used in harsh conditions	Avoid using vehicle in harsh conditions ,see <Safety>.
Vehicle needs a push to go forward	Poor contact of wires or Connectors	Check that the battery connectors are firmly plugged into each other. If wires are loose around the motor, <b>contact your distributor please.</b>
	"Dead Spot" on motor	A dead spot means the electric power is not being delivered to the terminal connection and the vehicle needs repair. <b>Contact your distributor please.</b>
Difficult shifting from forward to reverse or vice-versa	Attempting to shift while the vehicle is motion	Completely stop the vehicle and shift, see <Use Your New Vehicle>
Loud grinding or clicking noises coming from motor or gear box	Motor or gears are damaged	<b>Contact your distributor please.</b>
Battery will not recharge	Battery connector or adapter connector is loose	Check that the battery connectors are firmly plugged into each other.
	Charger not plugged in	Check that the battery charger is plugged into a working wall outlet.
	Charger is not working	<b>Contact your distributor please.</b>
Charger feels warm when recharging	This is normal and not a cause for concern	



Completely read through this manual and the troubleshooting guide table before calling. If you still need help resolving the problem **Contact your distributor please.**

## About Your New Vehicle

On the purchase of your new Ride-On.

This ride-on car will provide your child with many miles of riding of enjoyment. To help assure you and your rider a safe ride we ask you to please read this manual carefully, and keep it for future reference.

### Specification

<b>Suitable age:</b>	36-95 months
<b>Battery:</b>	6V4.5AH x1
<b>Charge time:</b>	8~12 hours
<b>Charge:</b>	Input: depend on local voltage output: DC6V500mA
<b>Load capacity:</b>	20 kg
<b>Size of car:</b>	68 x 39 x 44cm
<b>Speed:</b>	3km/h



#### PREVENT INJURIES AND DEATHS:

- **NEVER LEAVE CHILD UNATTENDED. ADULT DIRECT SUPERVISION IS REQUIRED.** Always keep child in view when child is in vehicle.
- This toy should be used with caution since skill is required to avoid falls or collisions causing injury to the user or third parties.
- Protective equipment should be worn.
- Not to be used in traffic.
- This toy is unsuitable for children under 36 months due to its maximum speed; Maximum user weight is 20 kg.
- This toy has no brake.

#### Disposal Of Battery



- Your sealed lead-acid battery must be recycled or disposed of in an environmentally sound manner.
- Do not dispose of your lead-acid battery in a fire. The battery may explode or leak.
- Do not dispose of a lead-acid battery in your regular, household trash. The incineration, land filling or mixing of sealed lead-acid batteries with household trash is prohibited by law.

Part name \_\_\_\_\_

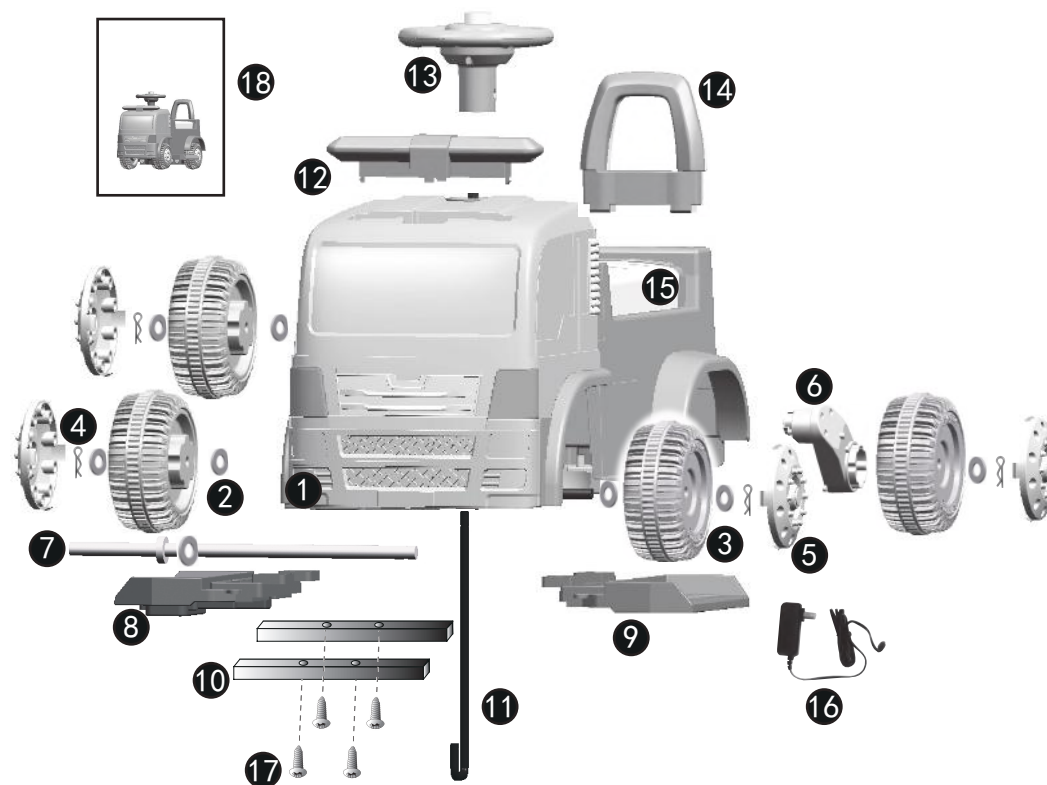

No.	Part name	Qty	No.	Part name	Qty
①	Car body	1	⑩	Square tube	2
②	Gasket	8	⑪	Steering lever	1
③	Wheel	4	⑫	Alarm lamp	1
④	Cotter	4	⑬	Steering wheel	1
⑤	Wheel cover	4	⑭	Back rest	1
⑥	Motor	1	⑮	Seat	1
⑦	Rear axle	1	⑯	Charger	1
⑧	Right foot rest	1	⑰	M4*12 Screw	4
⑨	Left foot rest	1	⑱	Guide book	1



## How to assemble

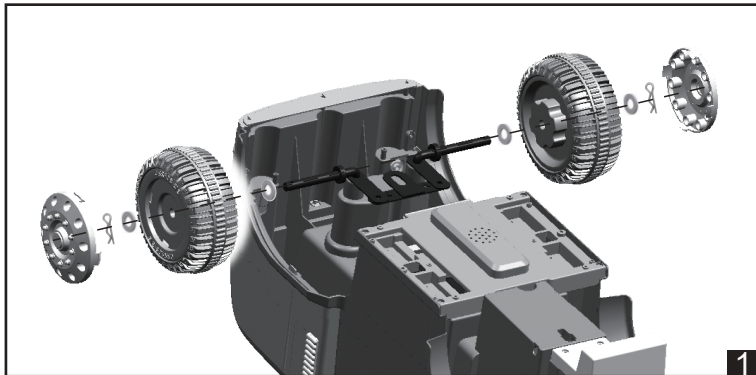

1. Add gasket, wheel, gasket, cotter and wheel cover to each side of steering wheel one by one. (P1)

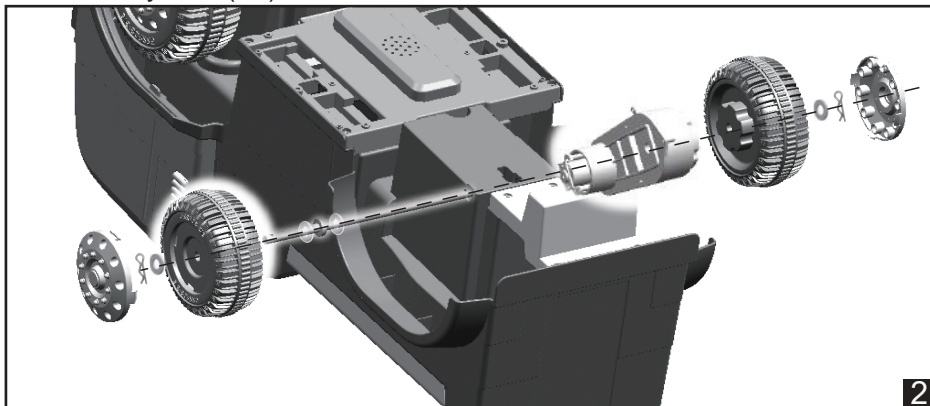

2. Add one gasket to rear axle from the right side, insert rear axle to car body. Add motor to the right side and add gasket to the left side. Then add wheel, gasket, cotter and wheel cover one by one. (P2)

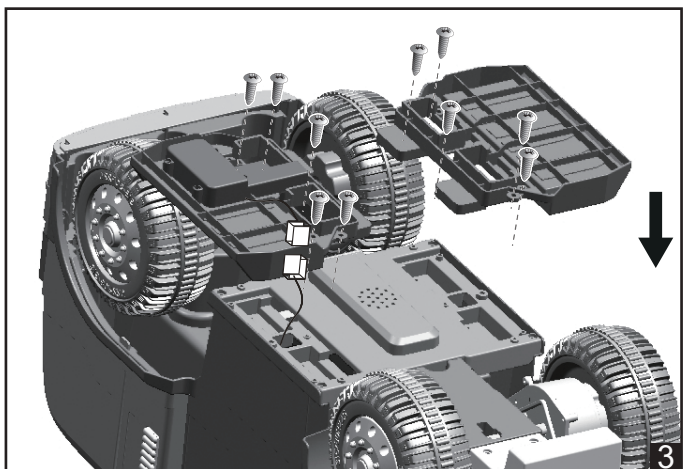

3. Connect two terminals of car body and foot rest, then assemble two foot rest according to the arrow and use 10pcs M4\*12 screw to tighten. (P3)

## How to assemble

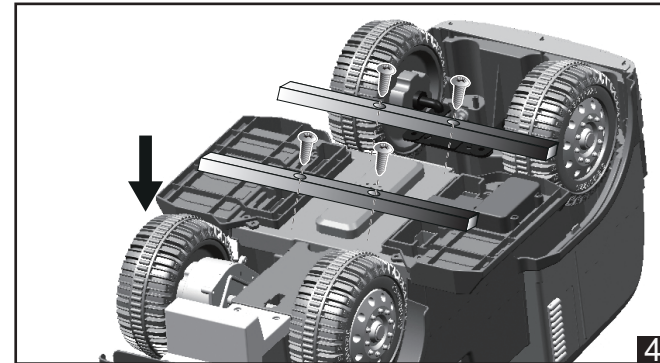

4. Assemble two square tubes to the car body according to the arrow, then use 4pcs M4\*12 screw to tighten.

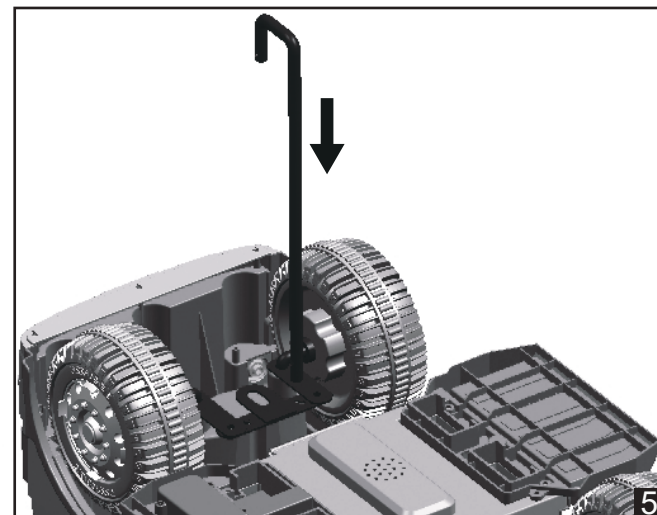

5. Insert the steering lever to the car body according to the arrow, then turn over body by holding up steering lever, in order to it falls.

## How to assemble

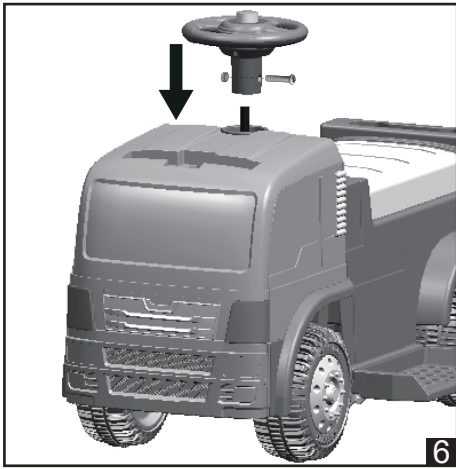

6. Insert steering wheel into the steering lever, then use screw to tighten. (P6)

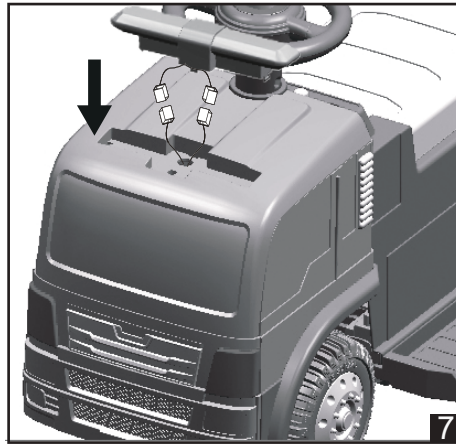

7. Connect two terminals of the alarm lamp and car body, insert alarm lamp to the car body according to the arrow. (P7)

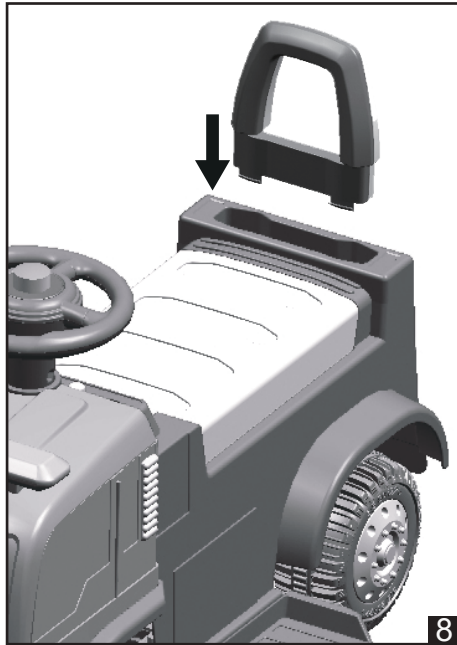

8. Insert the back rest in the car body. (P8)

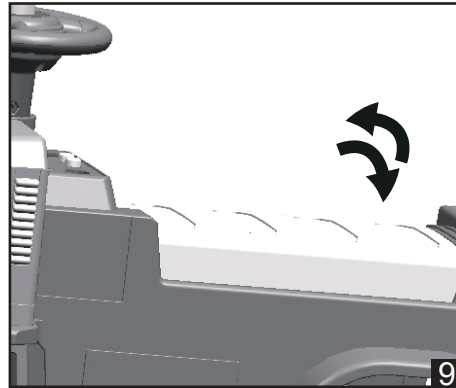

9. Open the seat according to the arrow. (P9)

## Function

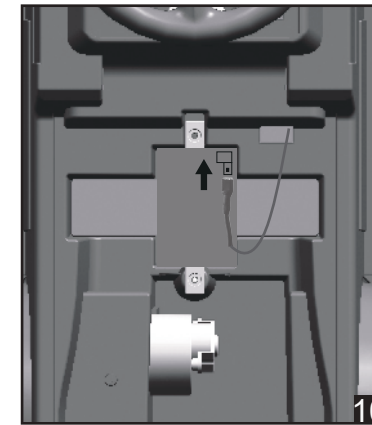

10. Connect the red line to the red terminal of battery. (P10)

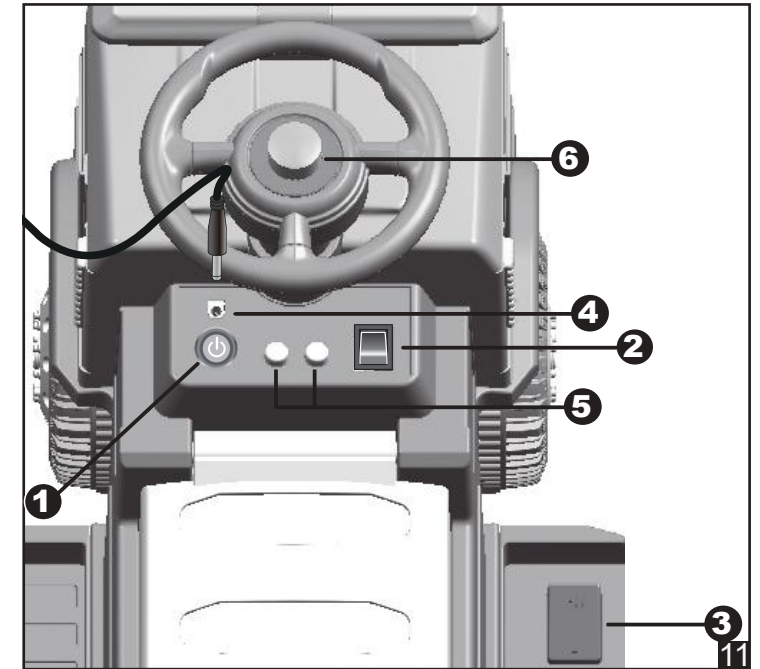

- 1** Turn the power, car is ready to play.
- 2** Forward, stop, backward button controls forward, stop, backward.
- 3** Step pedal switch, press forward button, car moves forward, press stop, car stops, press backward, car moves backward.
- 4** Charging hole is over the power switch. When power is low, please recharge. Car can not play when it is charging. Charging should be done by adults.)
- 5** Press music button for alarm sound and song. Press bellows button for "BEEP" sound