

Louver Roof Pergola Assembly Instruction

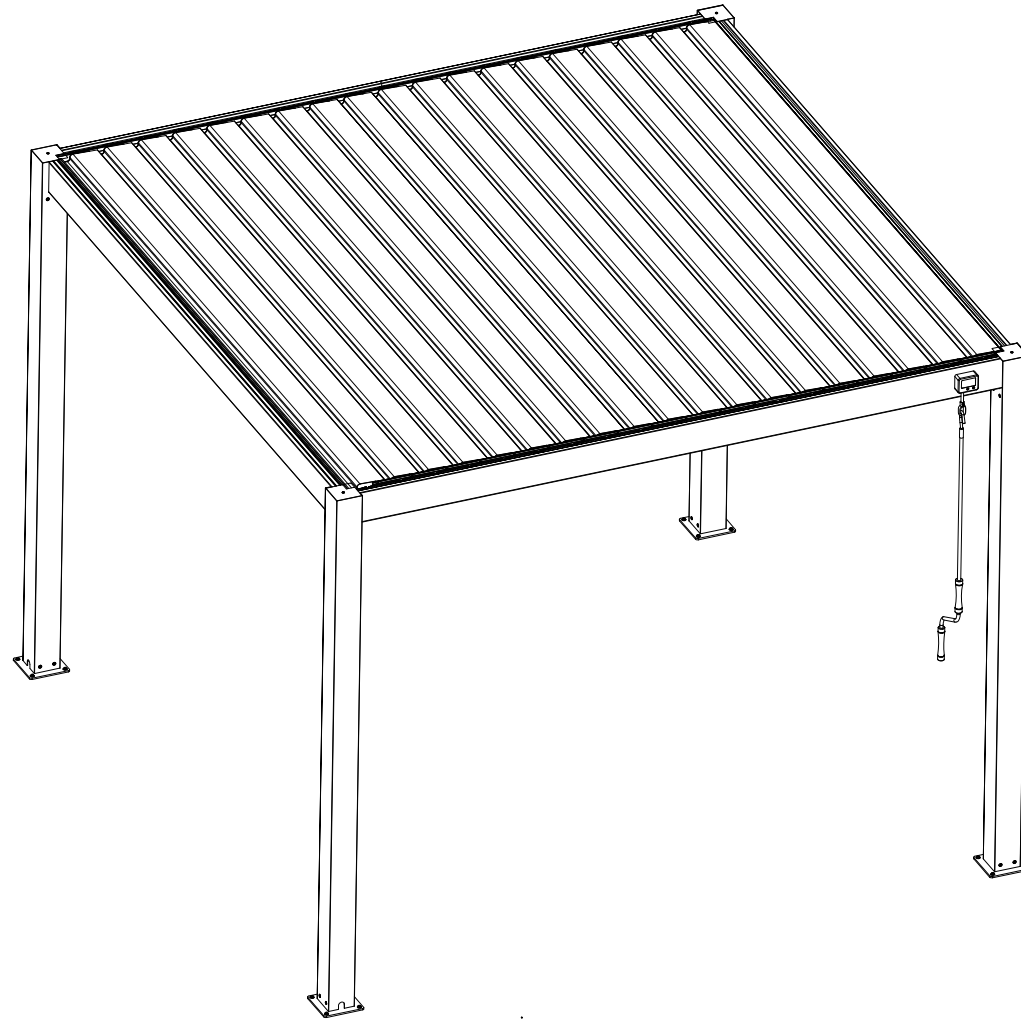

MODEL: HX-GAM3030

Product Size(LxWxH): 295x295x230cm

IMPORTANT

Please read the instructions carefully before you start to assemble this pergola.

Please ensure that you find all parts in the carton in the correct type and quantity as mentioned in the illustrated content list.

Please carry out the steps in the order set out in the instructions.

Tighten all screws and parts, after completed the assembly.

Keep the instructions in a safe place for future reference.

SAFETY ADVICE

- We strongly recommend the product to be assembled by at least 3-4 people.
- Do not attempt to assemble the pergola in windy or wet conditions.
- Do not position your pergola in an area exposed to excessive wind.
- Identify any possible hazards including underground and overhead power cables and underground water pipes etc.
- Always wear gloves, safety goggles, long sleeves and shoes when assembling or performing any maintenance on your product.
- Some parts may have sharp edges. Please be careful when handling components.
- When using a stepladder or power tools, make sure you follow the manufacturer's safety advice.
- Dispose of all plastic bags safety-keep them out of reach of children.
- Keep children away from the assembly area.
- Do not attempt to assembly the pergola if you are tired, have taken drugs or alcohol or if you are prone to dizzy spells.
- Do not climb or stand on the roof, to avoid falling down.
- Heavy snow load on roof will damage the product and making it unsafe to stand below or nearby. Please clean up the roof snow in time.
- Please open the roof louvre in the extreme weather to avoid the risk of damage.













CLEANING & MAINTENANCE









- When your pergola needs cleaning, use a mild detergent solution and rinse with clean water.
- Do not use acetone, abrasive cleaners or other special detergents to clean the product.
- Keep roof and gutter clear of snow, dirt and leaves.
- Hot items such as recently used grills, blowtorches etc, must not be stores in the pergola.
- Heavy articles should not be leaned against the poles.
- Do not hang or lay on the profiles.
- Put small component parts (screws etc) in a box, so they will not missing.
Some parts maybe surplus after assembly, it is recommended to keep them in a safe place for future use.

BEFORE ASSEMBLY

- Choose the site carefully before assembly, an unobstructed place, sheltered from strong winds is the best.
- Site surface needs to be flat and leveled.
- This pergola should be assembled on a solid foundation (such as concrete or asphalt) and anchored to the ground.
- Using gradienter during the installation, to keep gutters parallel to the ground and posts perpendicular to the ground.
- Sort the parts and check according to the contents parts list.
- Please consult your local authorities if any permits are required prior to constructing the product.







Componentry

PART	#	mm	Qty.
	W01	130*130*186	4
	W03	170*170*6	4
	W05	105*105*1	4
	W07	140*49*1.5	38
	W08	43*13*23	38
	W61A		1
	W62		1
	W63	1000	1
	W64	Ø25*90	1
	W65	86*67*36	1
	W66	Ø42*23	1
	W67		1

PART	#	mm	Qty.
	M01	M5(N)	1
	N01	Ø5*16*0.8	1
	N02	Ø5*25*1.5	1
	N03	Ø8*Ø13*1	38
	Z01	Ø4.2*22	152
	Z02	Ø4.2*22	3
	Z04	M8*80	16
	N04	Ø9*18	38
	N05	Ø6*12	38



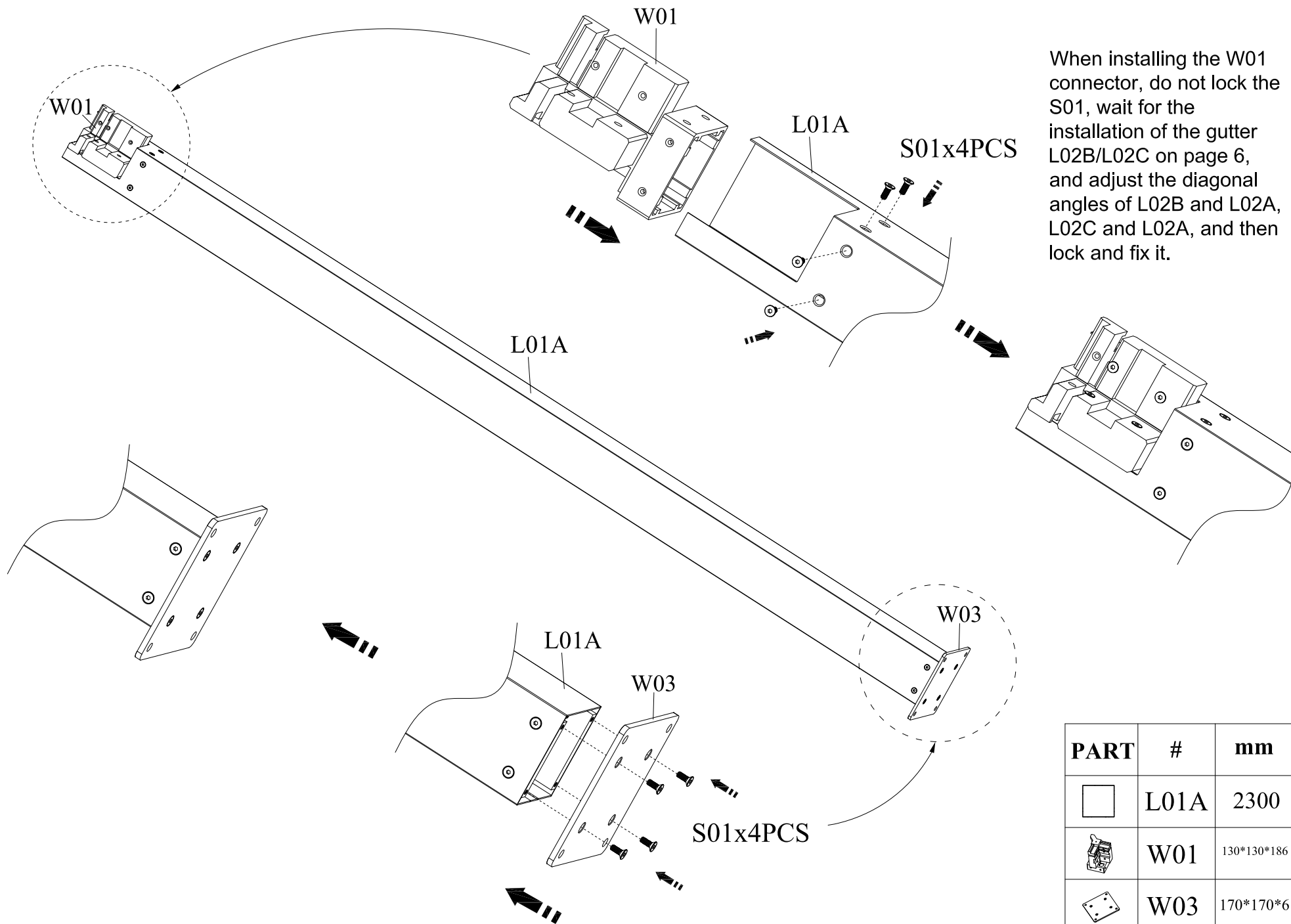

PART	#	mm	Qty.
	T04	4*65	1

PART	#	mm	Qty.
	S01	M6*16	48
	S02	M5*12	3
	S03	M5*40	3
	S04	M5*8	2
	S05	M5*25	1
	S07	M5*12	4



PART	#	mm	Qty.
	L01A	2300	4
	L02A	2801	2
	L02B	2801	1
	L02C	2801	1
	L03	2771	19
	L04	2668	2

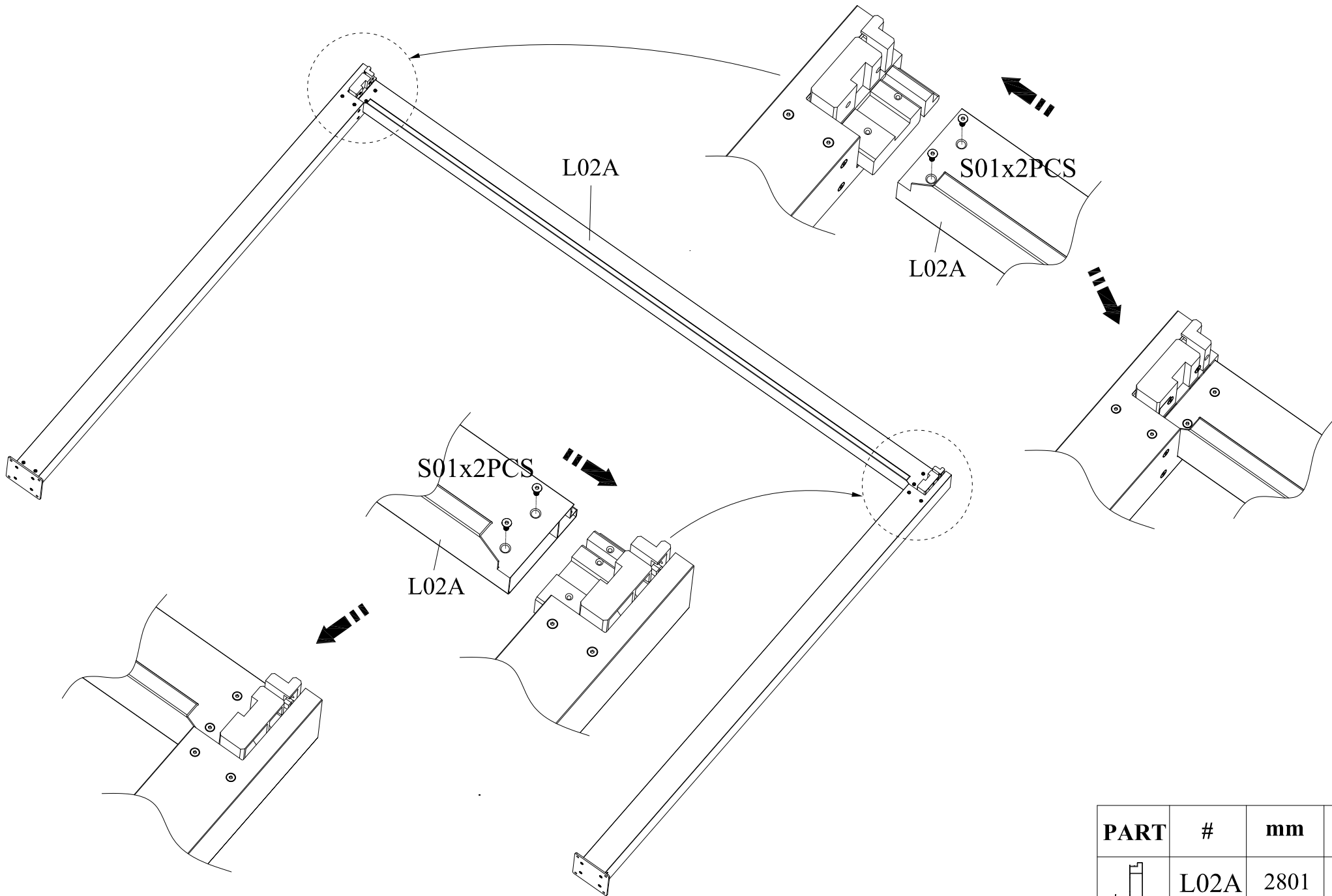

When installing the W01 connector, do not lock the S01, wait for the installation of the gutter L02B/L02C on page 6, and adjust the diagonal angles of L02B and L02A, L02C and L02A, and then lock and fix it.

PART	#	mm	Qty.
	L01A	2300	4
	W01	130*130*186	4
	W03	170*170*6	4
	S01	M6*16	32



PART	#	mm	Qty.
	L02A	2801	2
	S01	M6*16	8

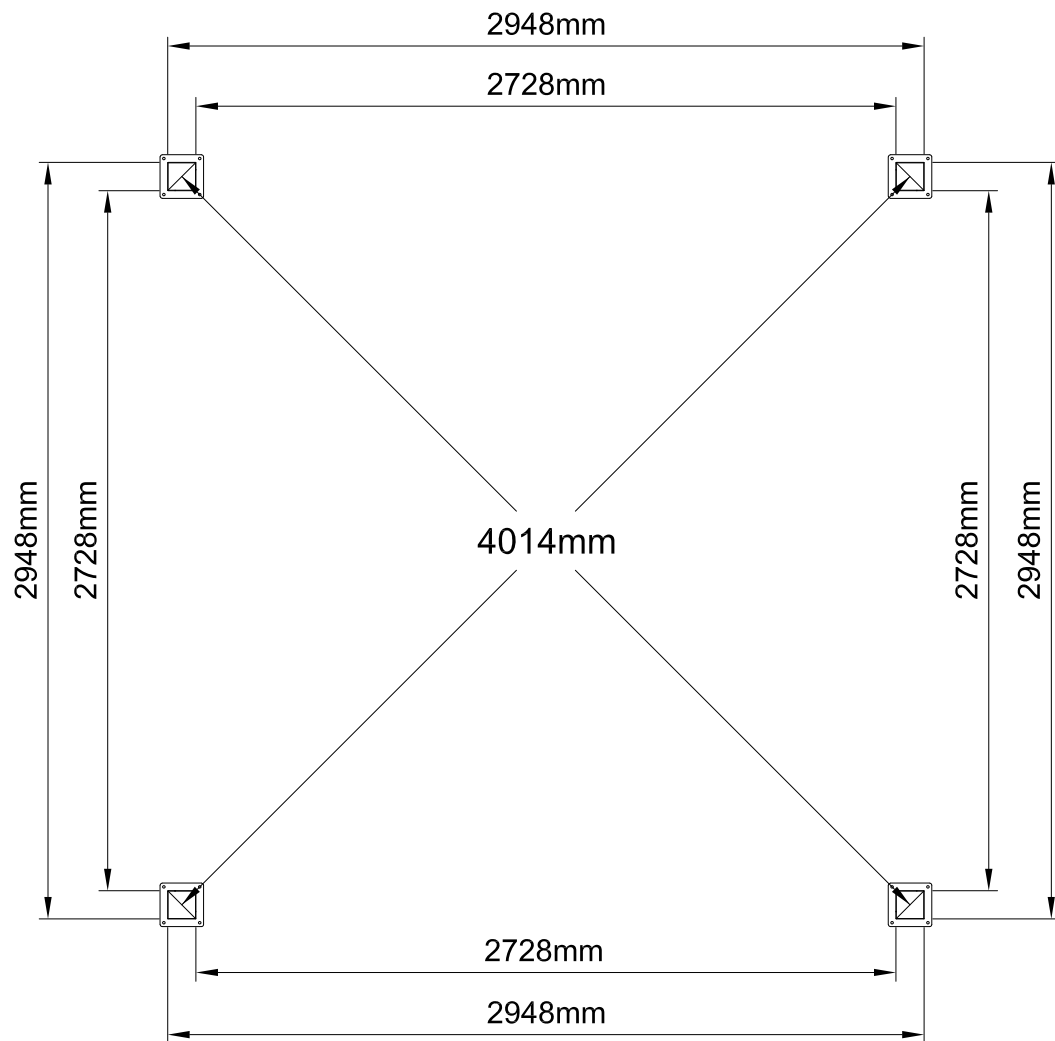

For the stability of product installation,
please make sure to pour 350x350x350mm
concrete at the bottom of each column

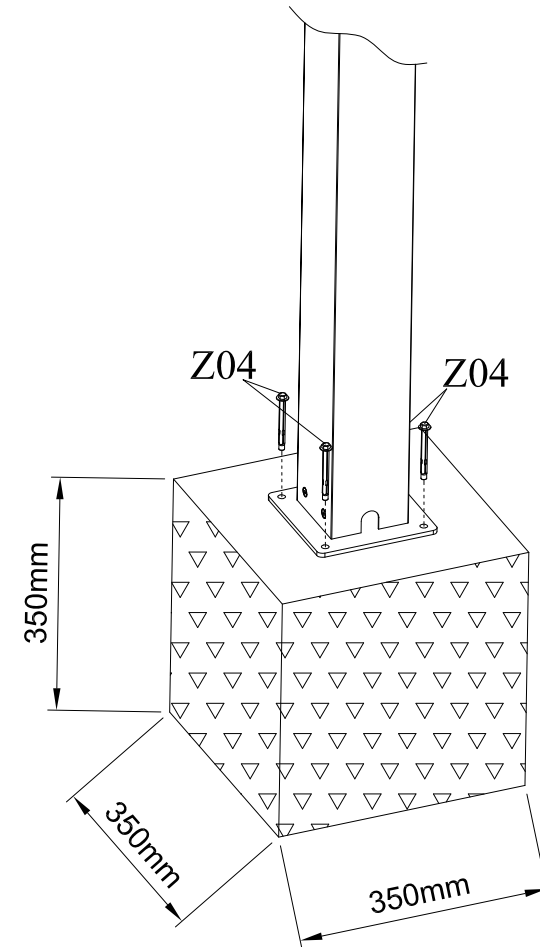



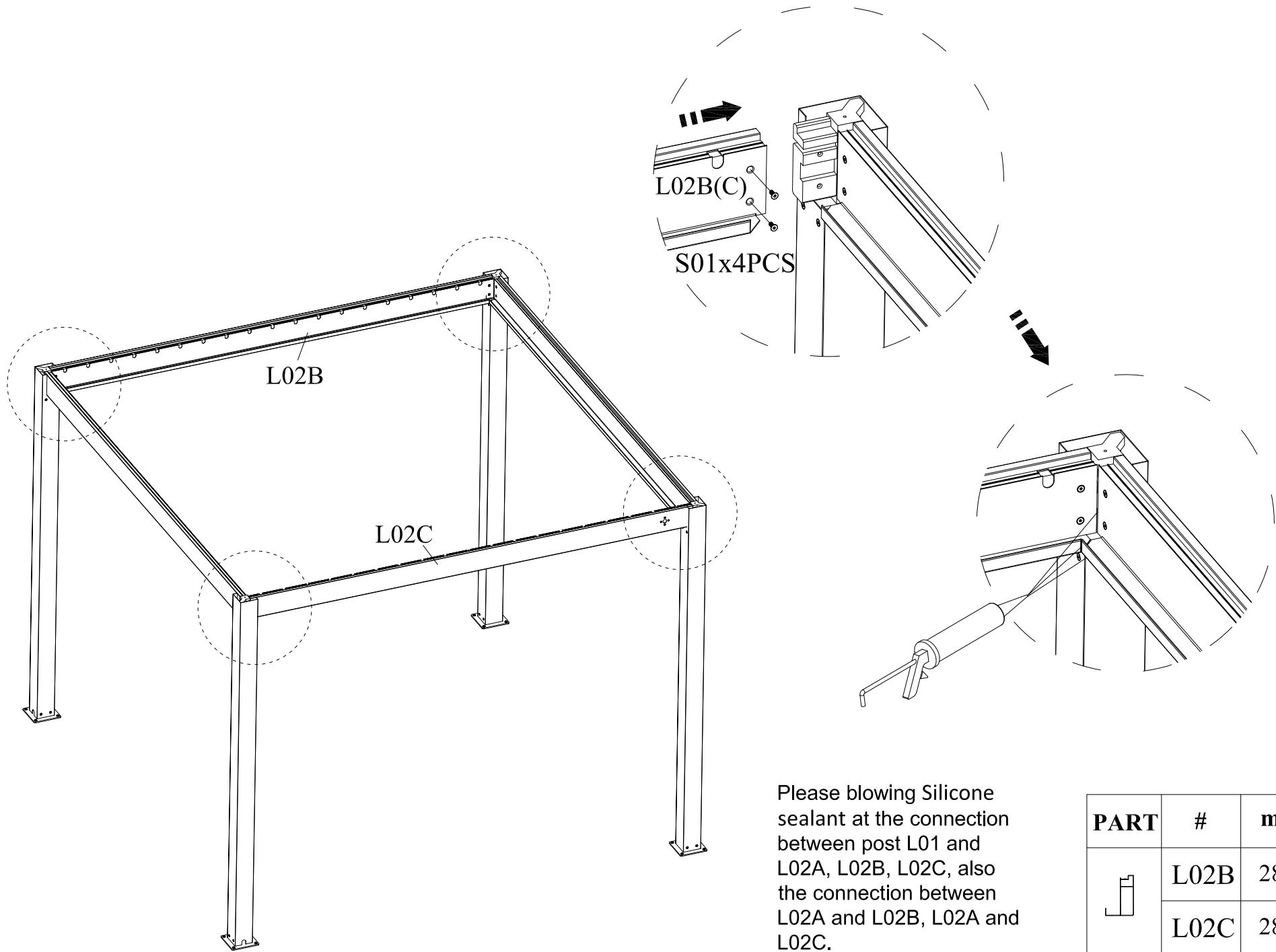

PART	#	mm	Qty.
	Z04	M8*80	16

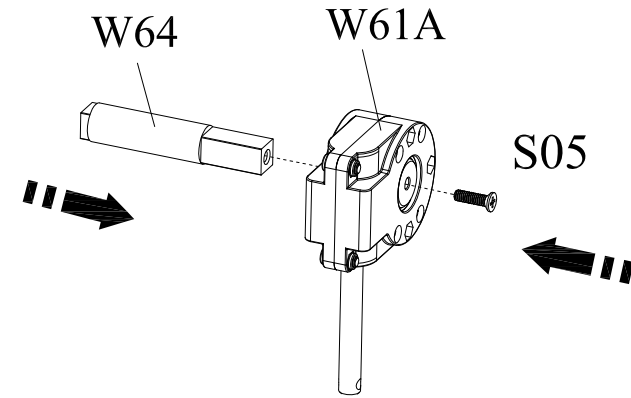
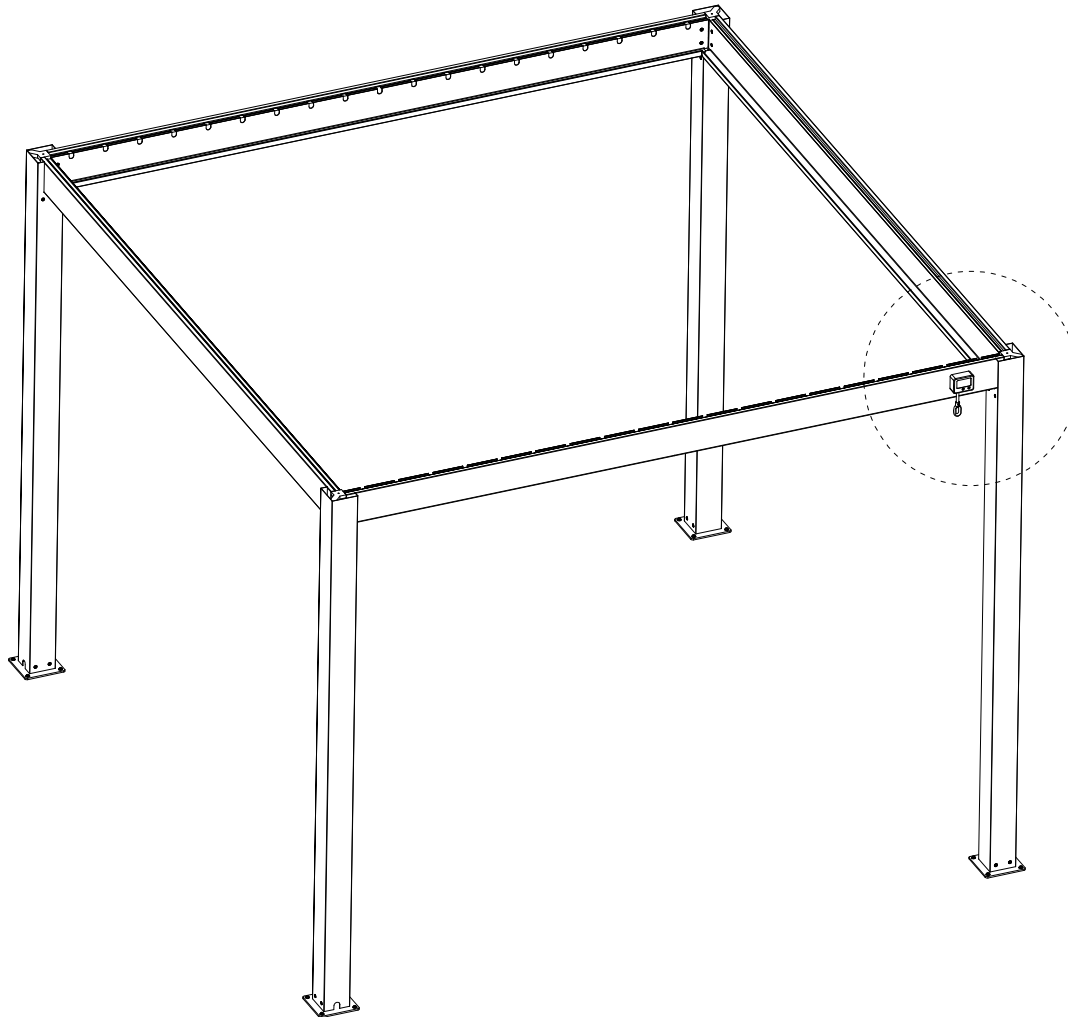

Please blowing Silicone sealant at the connection between post L01 and L02A, L02B, L02C, also the connection between L02A and L02B, L02A and L02C.



PART	#	mm	Qty.
	L02B	2801	1
	L02C	2801	1
	S01	M6*16	8



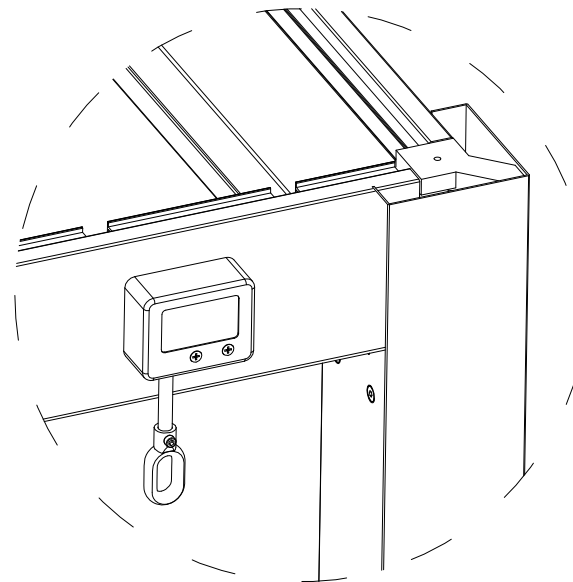
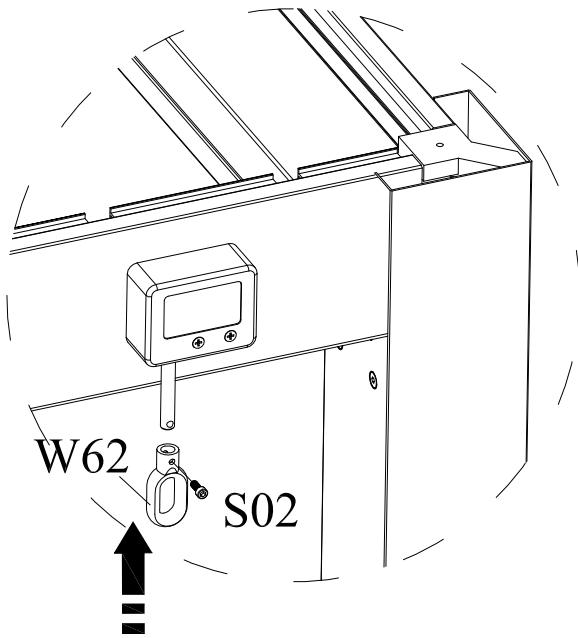
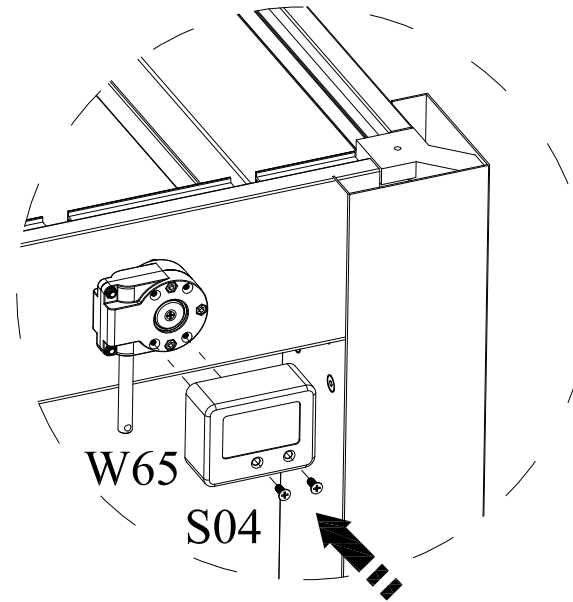
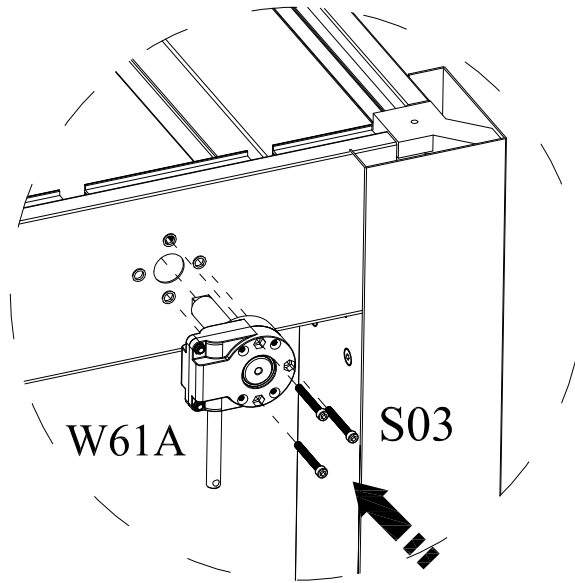

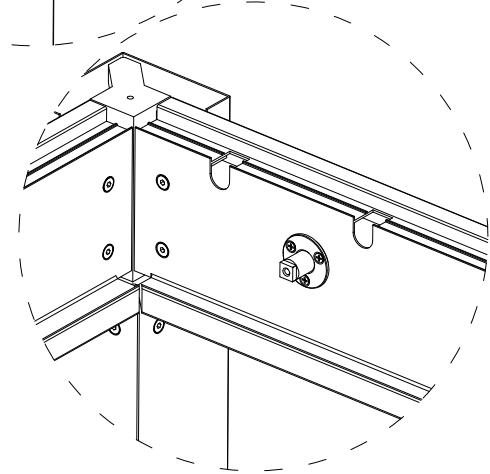
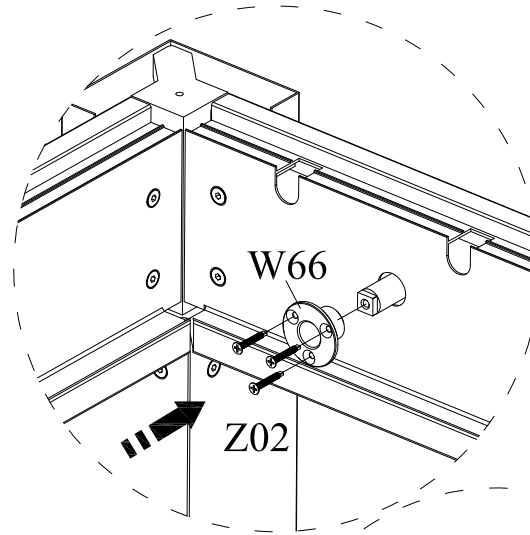
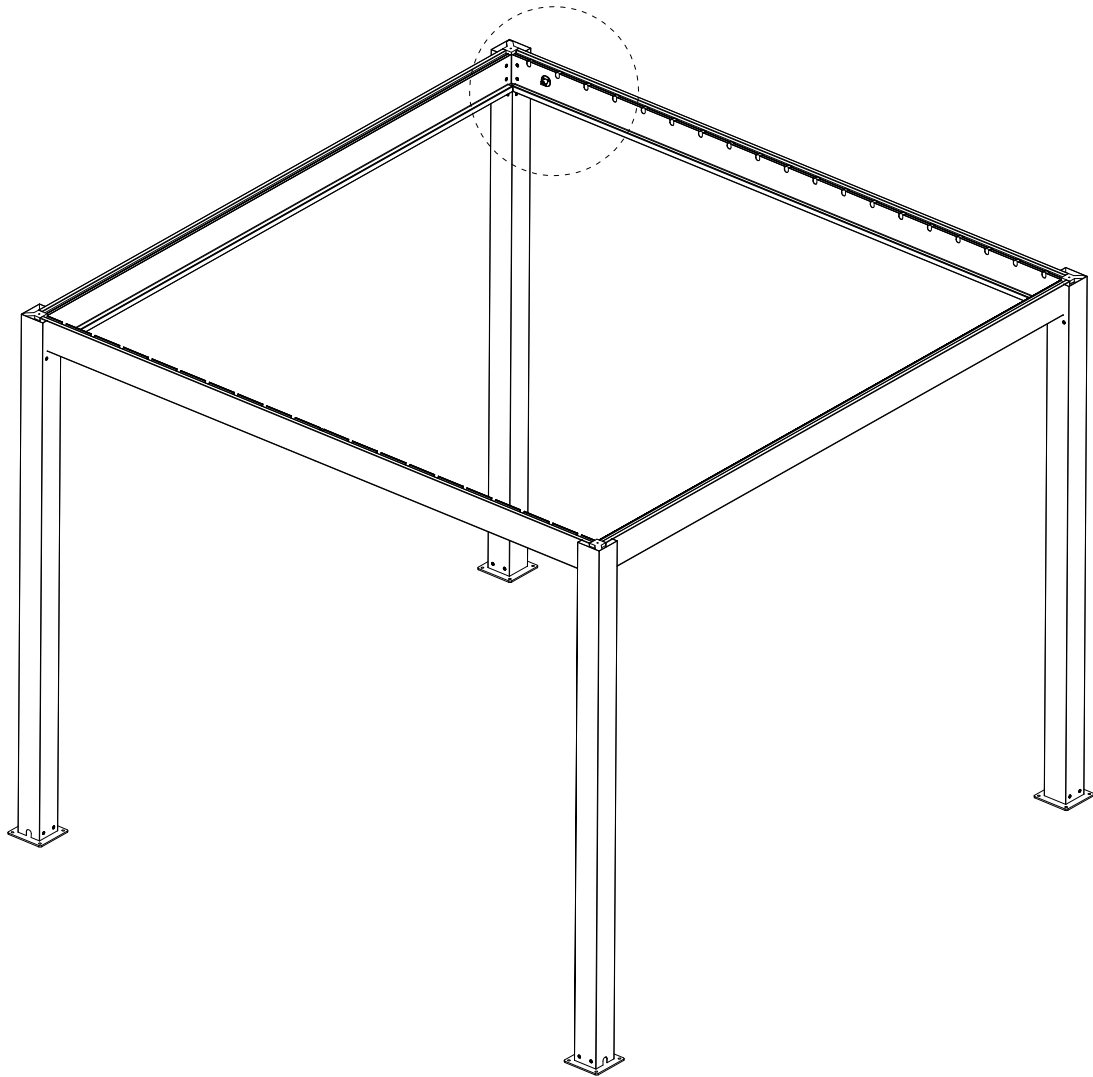

PART	#	mm	Qty.
	W61A		1
	W62		1
	W64	Ø25*90	1
	W65		1
	S02	M5*12	1
	S03	M5*40	3
	S04	M5*8	2
	S05	M5*25	1



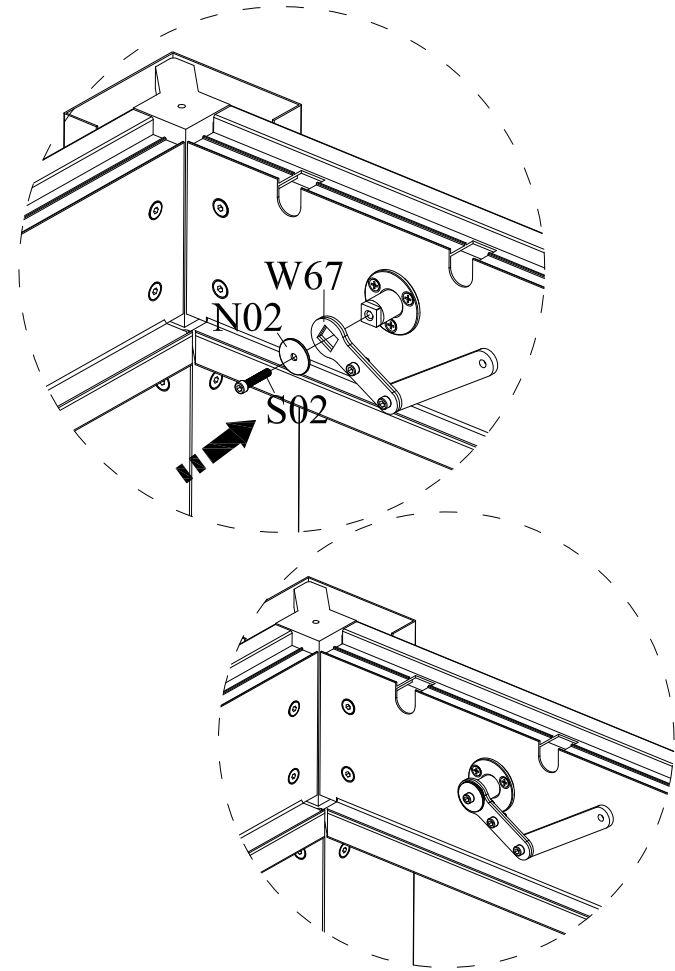
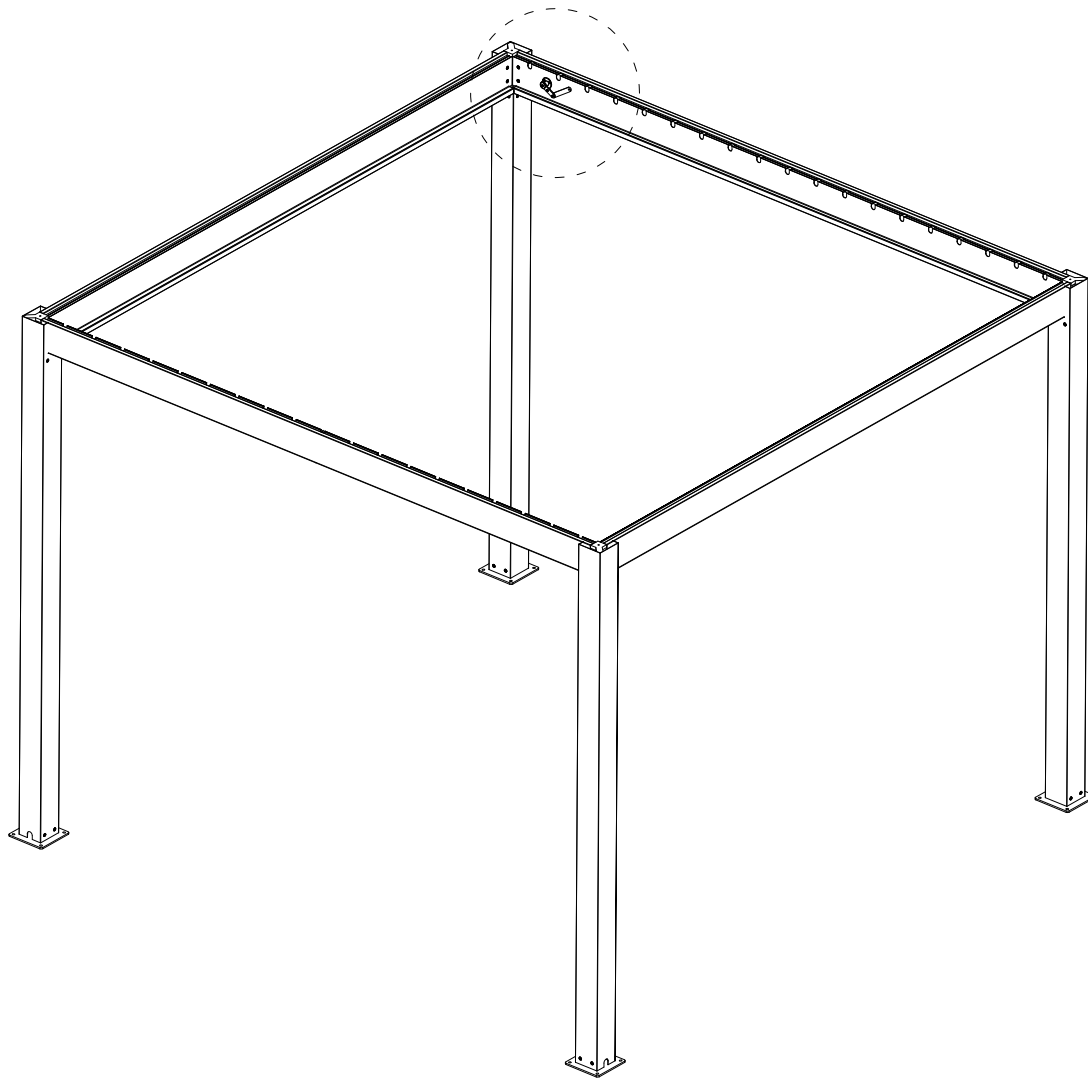





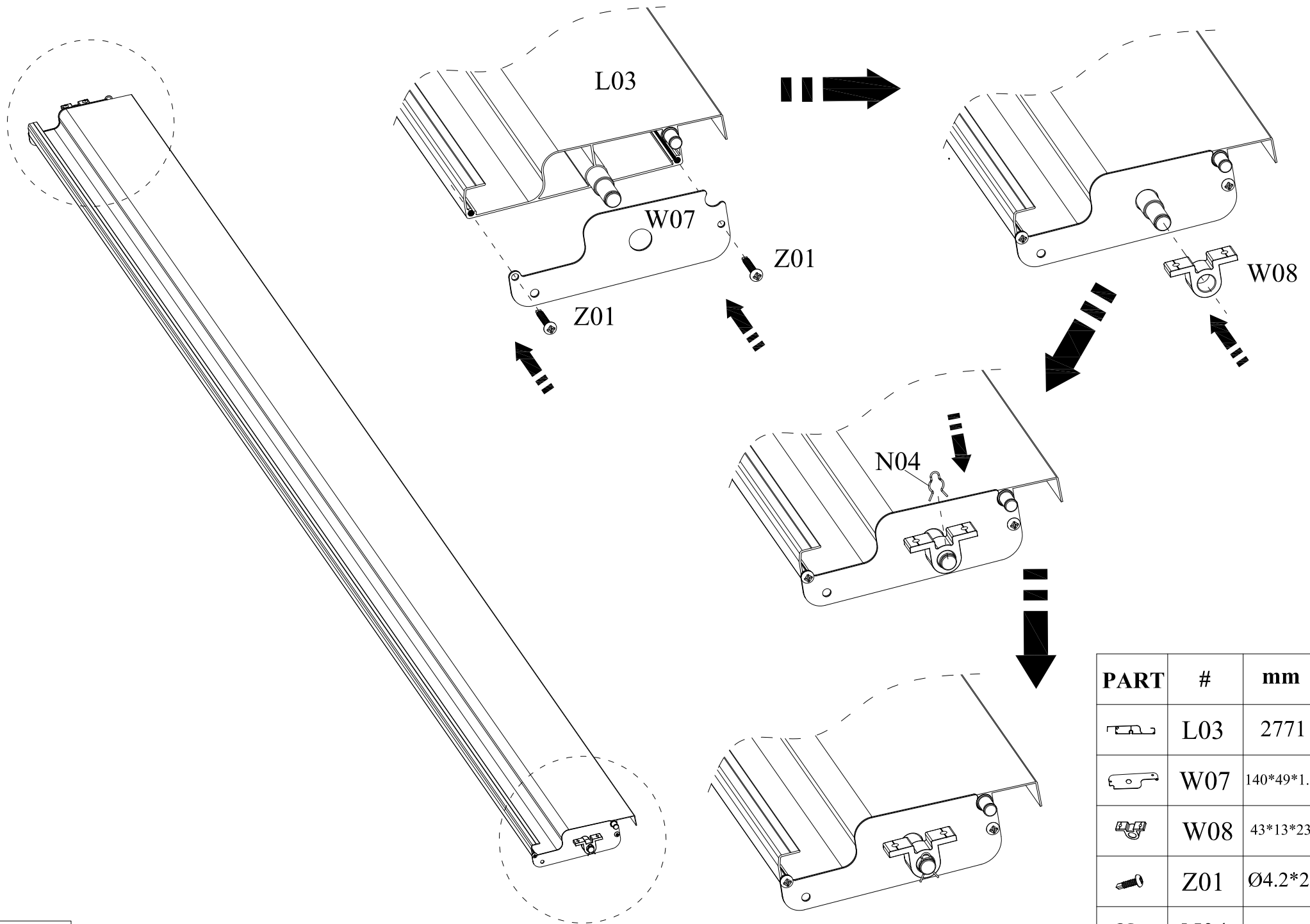

PART	#	mm	Qty.
	W66	Ø42*23	1
	Z02	Ø4.2*22	3



PART	#	mm	Qty.
	W67		1
	N02	Ø5*25*1.5	1
	S02	M5*12	1



PART	#	mm	Qty.
	L03	2771	19
	W07	140*49*1.5	38
	W08	43*13*23	38
	Z01	Ø4.2*22	76
	N04	Ø9*18	38

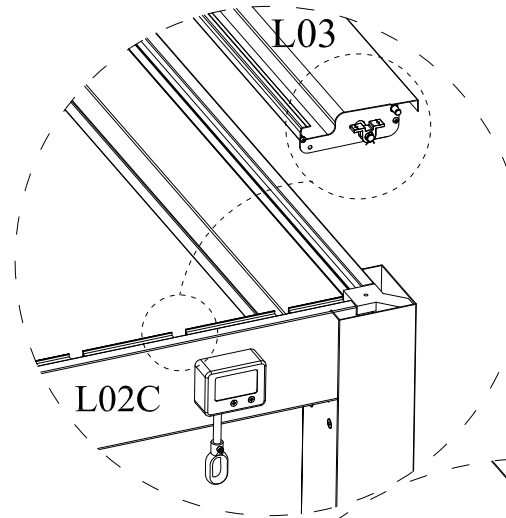
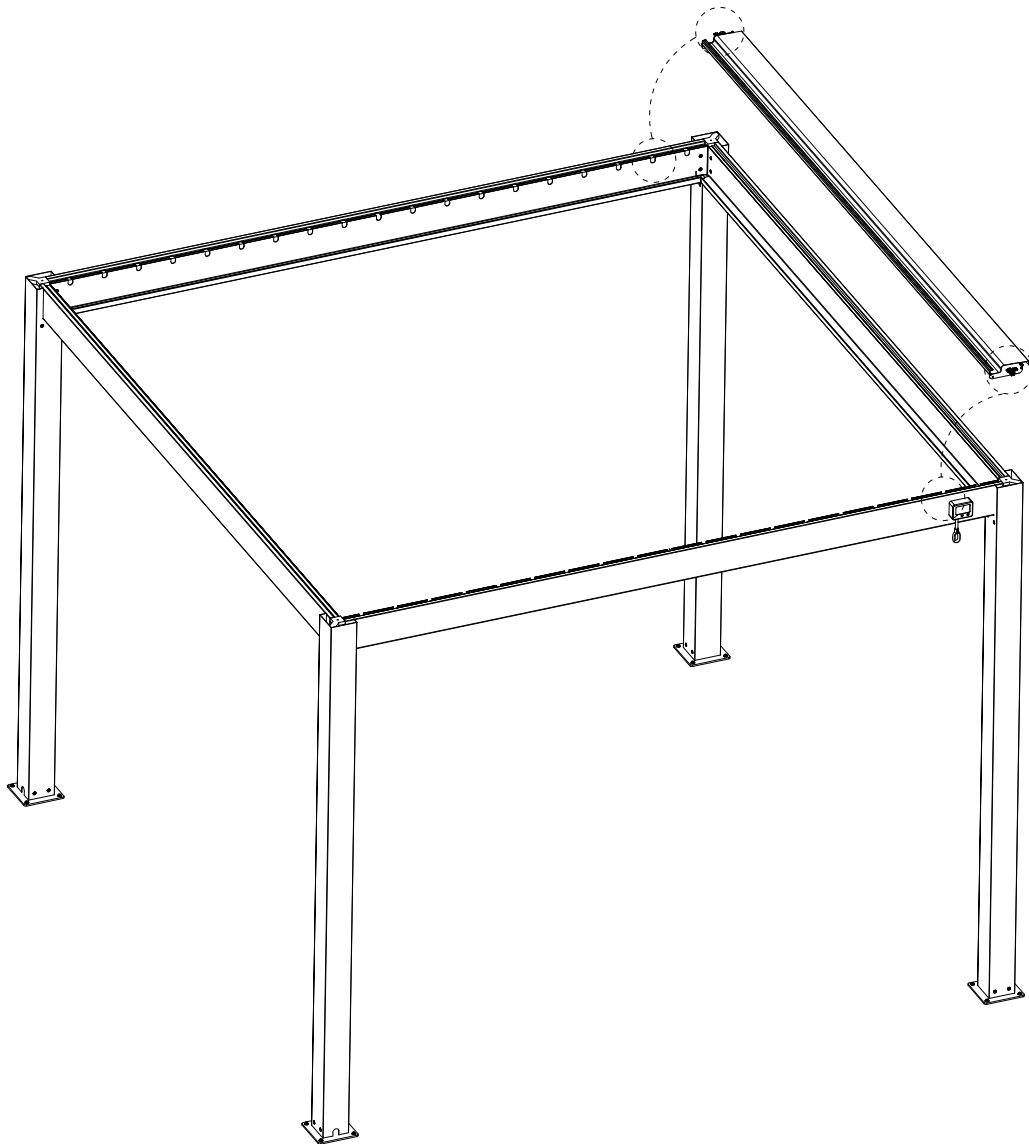

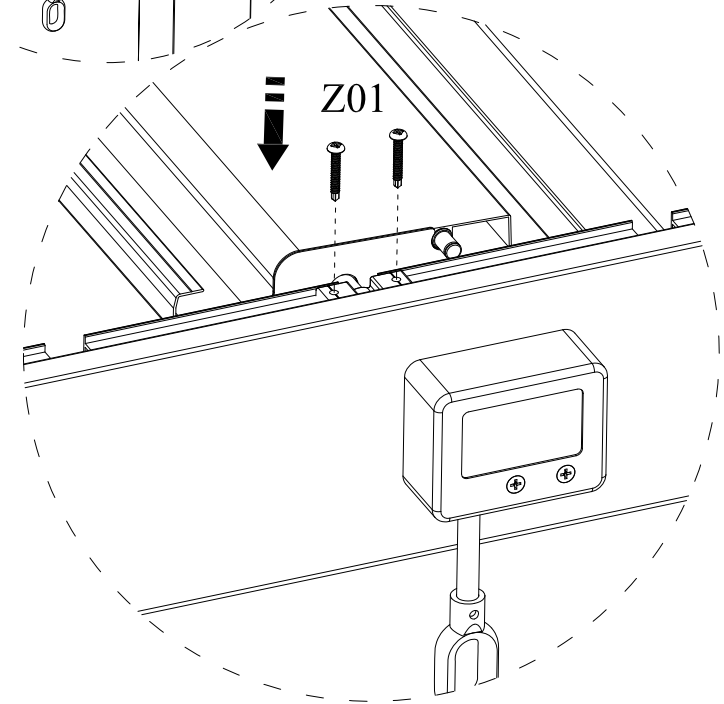

Put the assembled blade L03 into the second U-shaped slot of L02C, and then fix it with Z01.

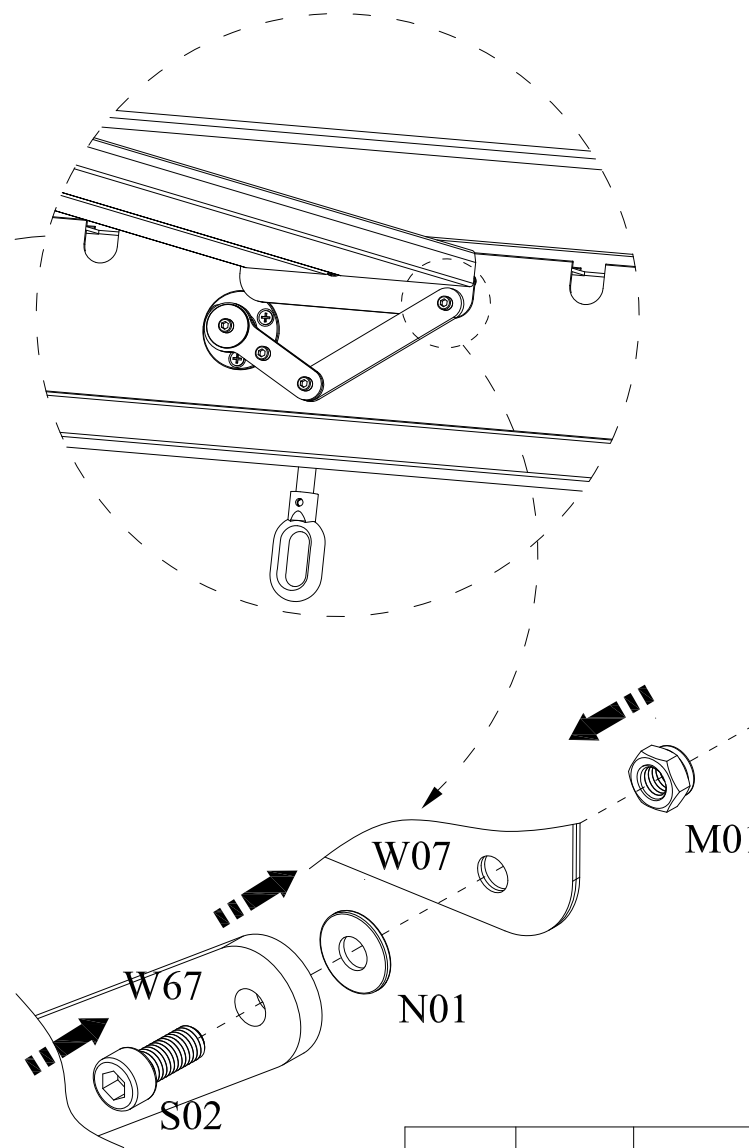
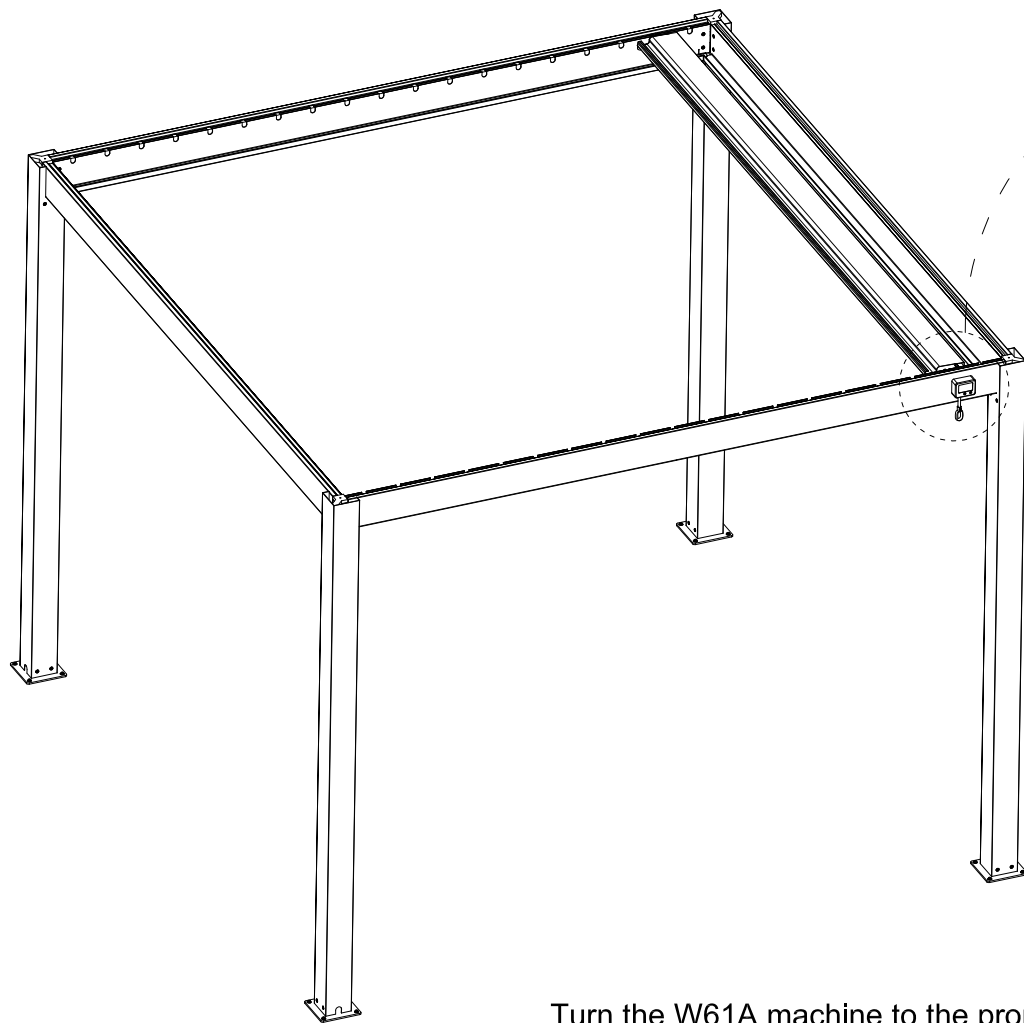

PART	#	mm	Qty.
	Z01	Ø4.2*22	4



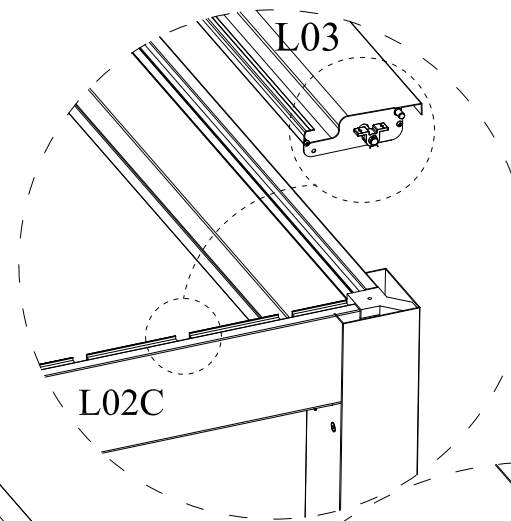
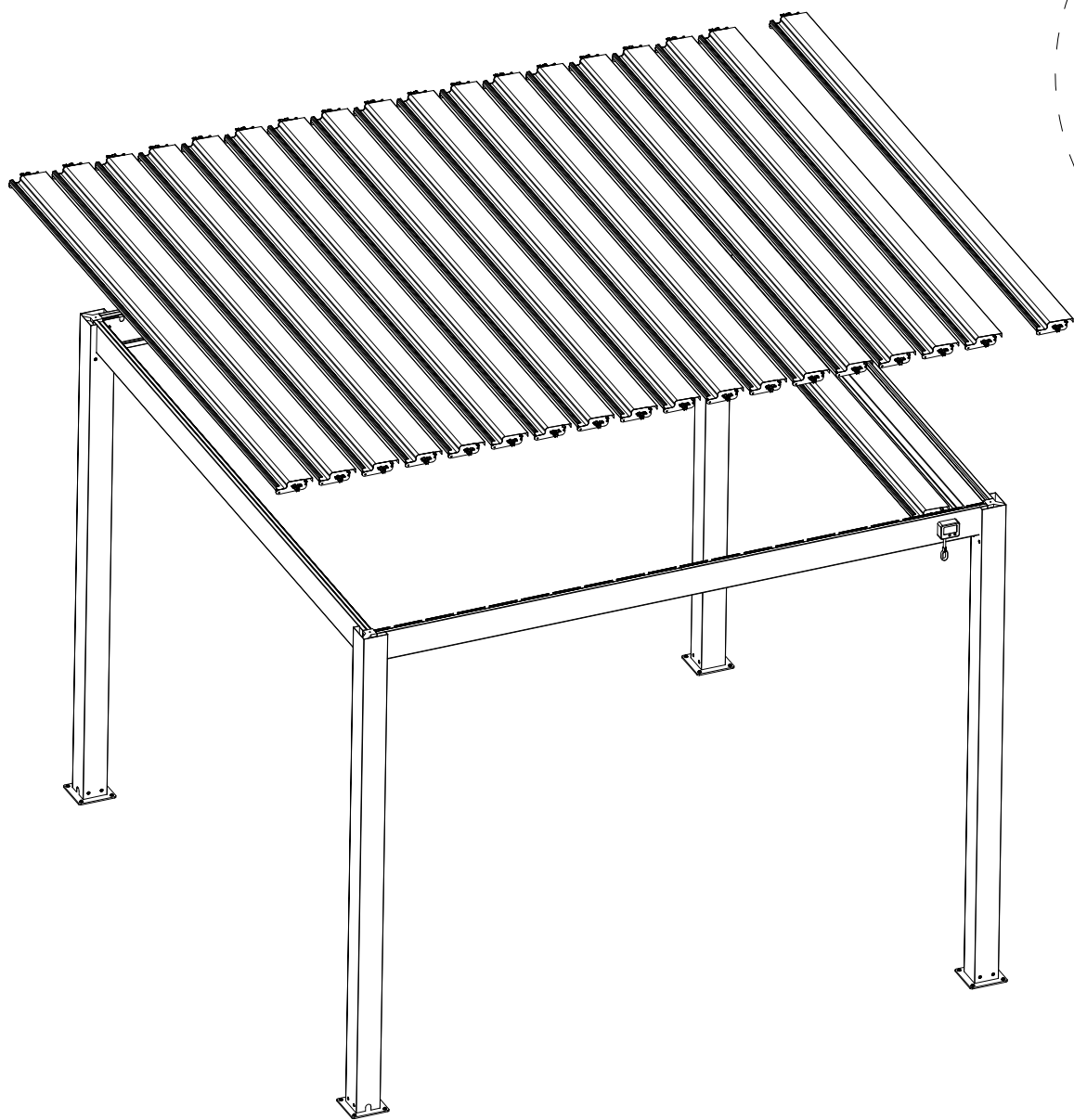

Turn the W61A machine to the proper position and connect W67 and W07 with S02 and M01. N03 is put between W67 and W07, and S02 should not be screwed too tightly to ensure that W67 and W07 can turn flexibly.

PART	#	mm	Qty.
	N01	Ø5*16*0.8	1
	S02	M5*12	1
	M01	M5(N)	1

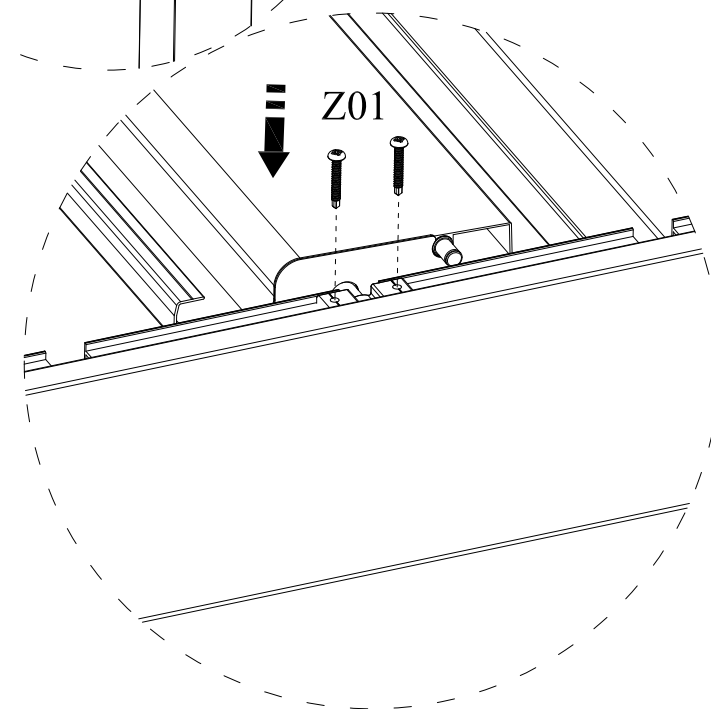

Put the rest of the assembled blade L03 into the U-shaped groove of L02C, and then fix it with Z01



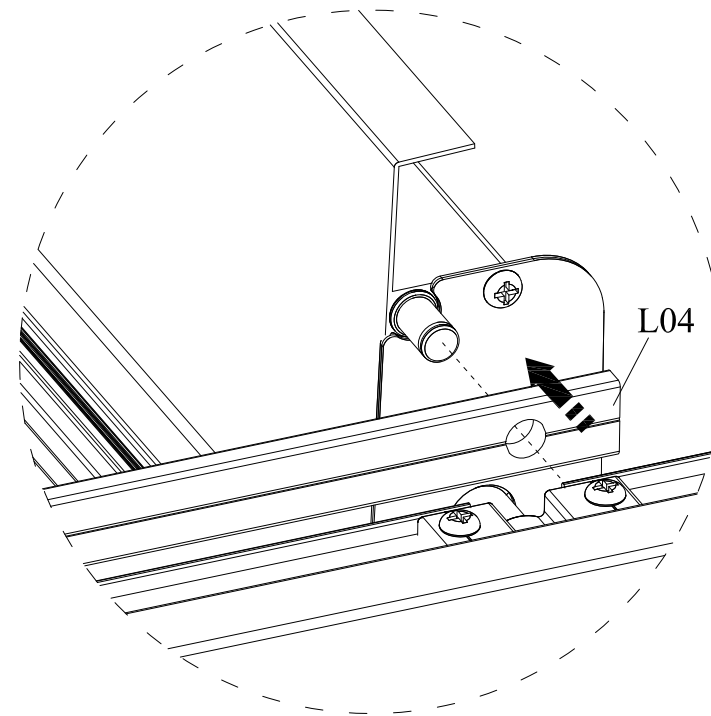
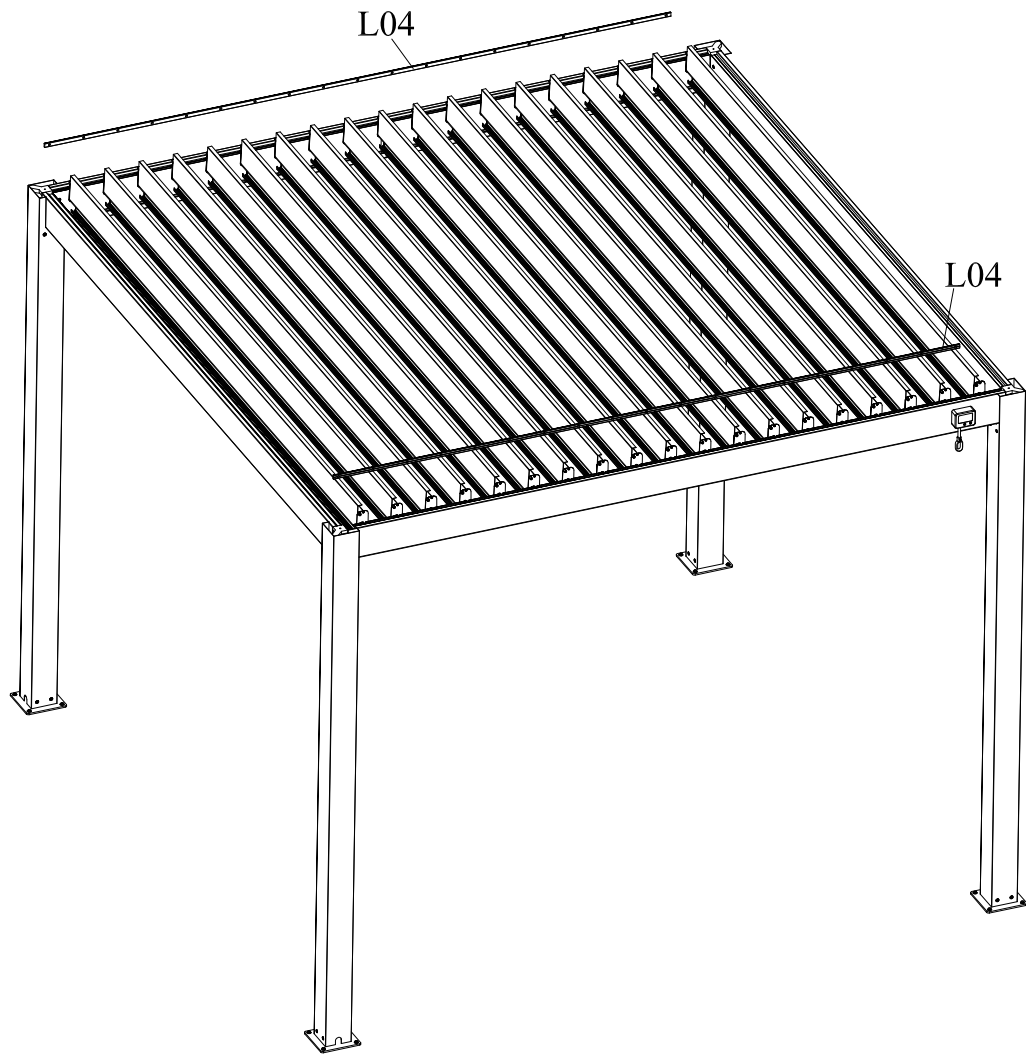

PART	#	mm	Qty.
	Z01	Ø4.2*22	68



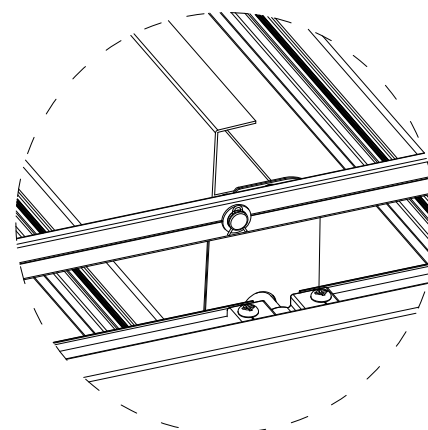
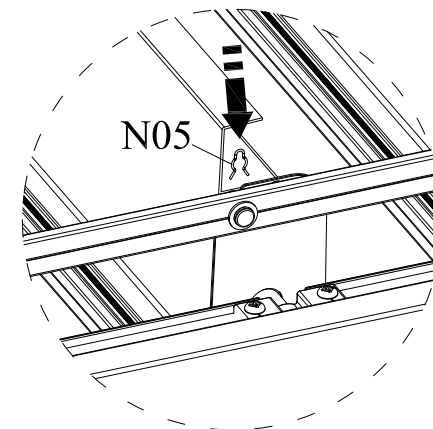
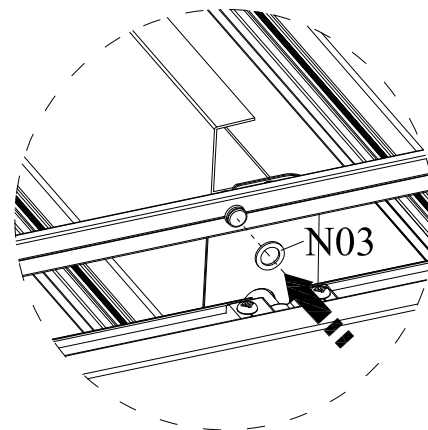
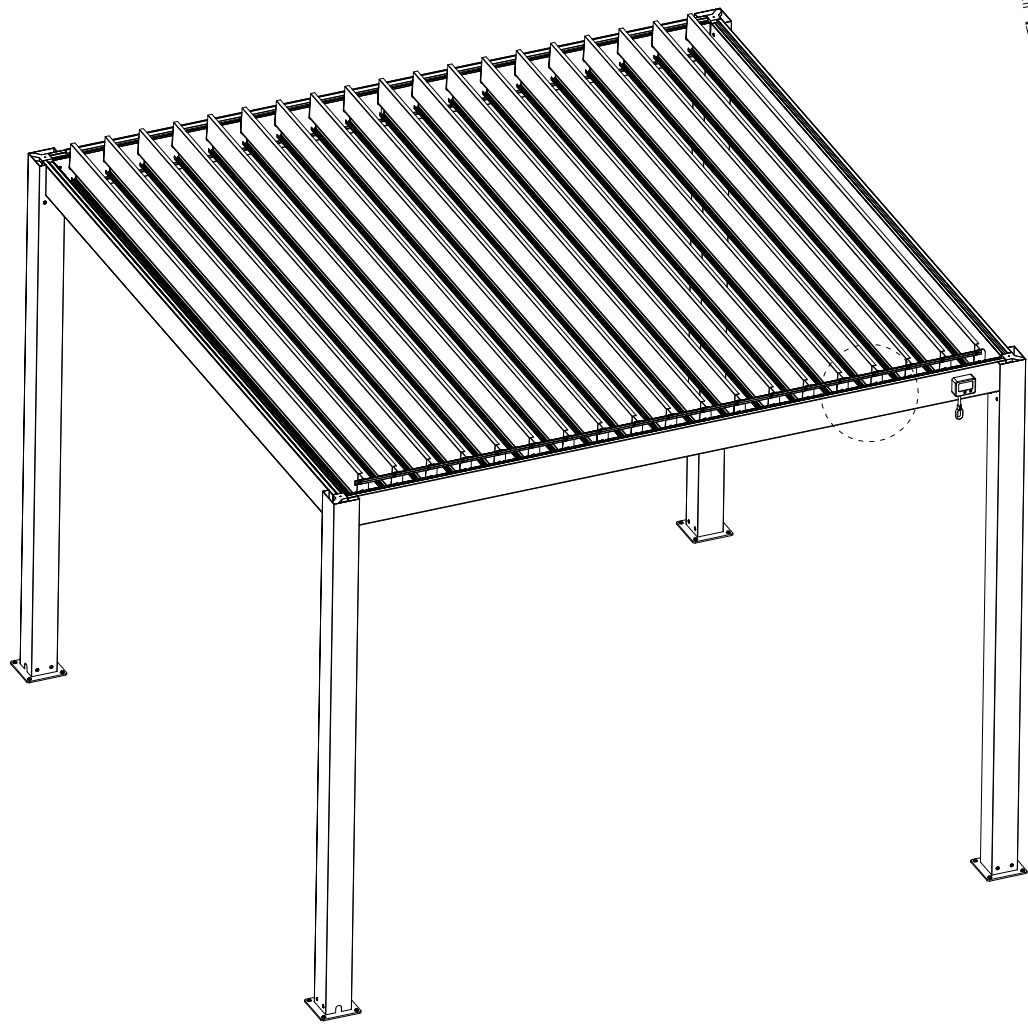

PART	#	mm	Qty.
	L04	2668	2

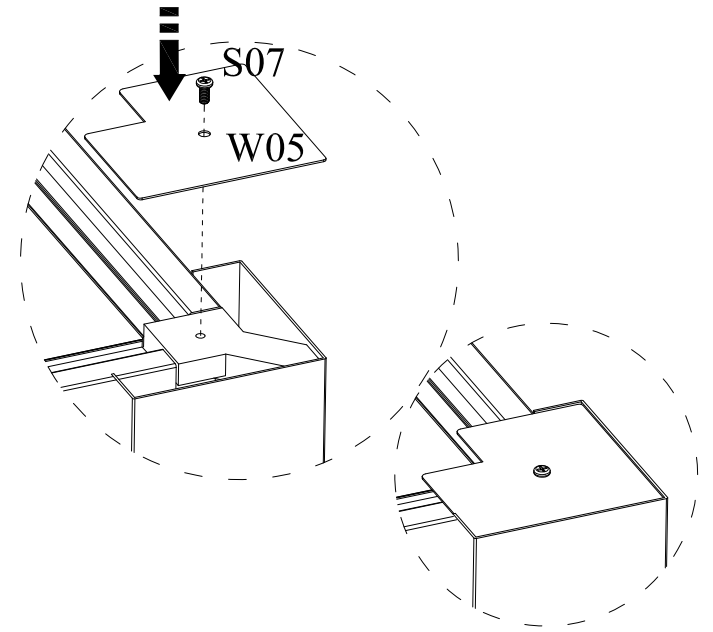
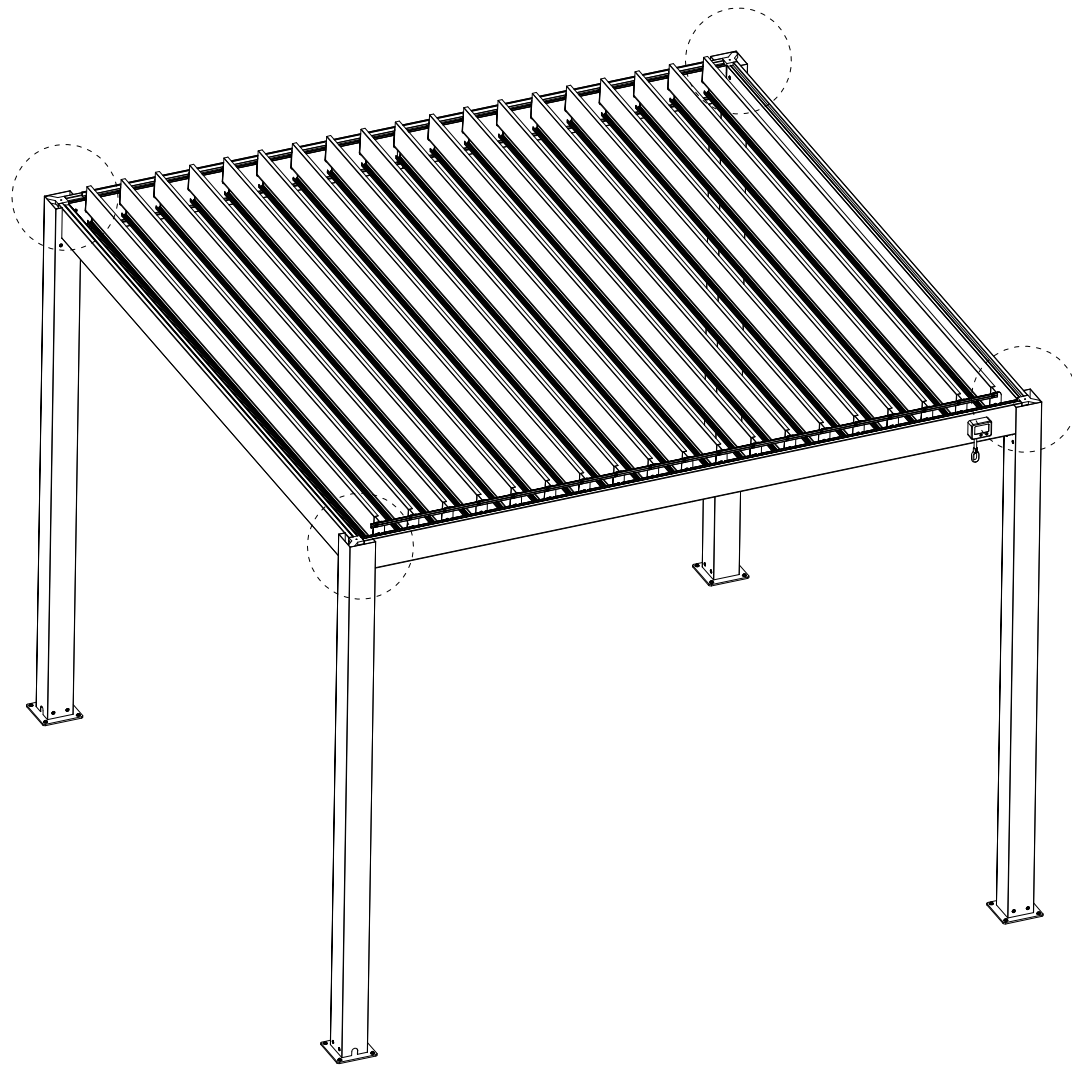

PART	#	mm	Qty.
	N03	Ø8*Ø13*1	38
	N05	Ø6*12	38



PART	#	mm	Qty.
	W05	105*105*1	4
	S07	M5*12	4

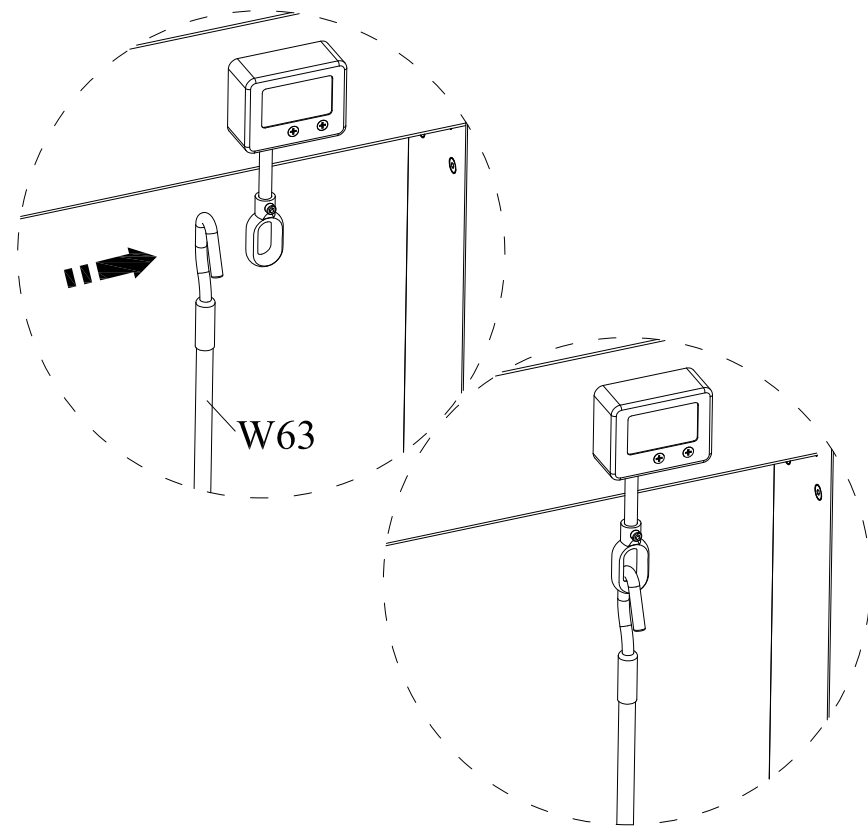

PART	#	mm	Qty.
	W63	1000	1

