



EN



WINE COOLER

USER MANUAL



Warning:
Before using this product,
please read this manual carefully
and keep it for future reference.
The design and specifications
are subject to change without
prior notice for product
improvement. Consult with your
dealer or manufacturer for
details.

version:002-6-2020

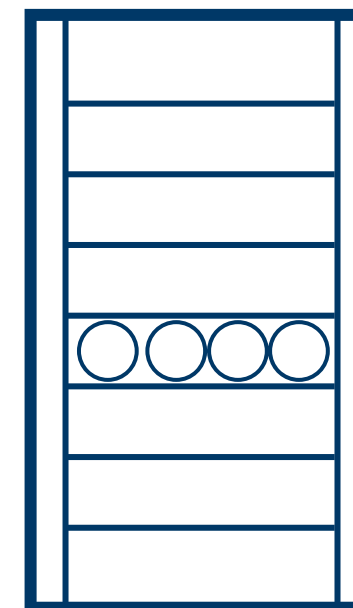

www.midea.com

CONTENTS

1 Safety warnings

1.1 Warning	1-2
1.2 Meaning of safety warning symbols	3
1.3 Electricity related warnings	3
1.4 Related warnings for use	4
1.5 Warnings related to placing items	5
1.6 Warnings for energy	5
1.7 Warnings related to disposal	5

2 Proper use of the cellar

2.1 Names of components	6
2.2 Temperature Control	7
2.3 Placement	7
2.4 Start to use	7
2.5 The arrangement of bottle	7
2.6 Usage of temperature zones inside the cellar	7
2.7 Energy saving tips	7
2.8 the storage temperature range of this product	8
2.9 Reversing the door swing	8-9

3 Maintenance of the cellar

3.1 Do not use for a short time	10
3.2 Do not use for a long time	10
3.3 Clean the cellar	10

4 Trouble shooting

DEAR CUSTOMER:

Thank you for buying this beverage cellar. To ensure that you get the best results from your new beverage cellar, please take time to read through the simple instructions in this booklet. Please ensure that the packing material is disposed of in accordance with the current environmental requirements. When disposing of any beverage cellar equipment please contact your local waste disposal department for advice on safe disposal. This appliance must be only used for its intended purpose.

1 Safety warnings

1.1 Warning



Warning: risk of fire / flammable materials

This appliance is intended to be used in household and similar applications such as staff kitchen areas in shops, offices and other working environments; farm houses and by clients in hotels, motels and other residential type environments; bed and breakfast type environments; catering and similar non-retail applications.

This appliance is not intended for use by persons (including children) with reduced physical, sensory or mental capabilities, or lack of experience and knowledge, unless they have been given supervision or instruction concerning use of the appliance by a person responsible for their safety.

Children should be supervised to ensure that they do not play with the appliance.

If the supply cord is damaged, it must be replaced by the manufacturer, its service agent or similarly qualified persons in order to avoid a hazard.

Do not store explosive substances such as aerosol cans with a flammable propellant in this appliance.

The appliance has to be unplugged after use and before carrying out user maintenance on the appliance.

Warning: Keep ventilation openings, in the appliance enclosure or in the built-in structure, clear of obstruction.

Warning: Do not use mechanical devices or other means to accelerate the defrosting process, other than those recommended by the manufacturer.

Warning: Do not damage the refrigerant circuit.

Warning: Do not use electrical appliances inside the food storage compartments of the appliance, unless they are of the type recommended by the manufacturer.

Warning: Please abandon the refrigerator according to local regulators for its use flammable blowing gas and refrigerant.

Warning: When positioning the appliance, ensure the supply cord is not trapped or damaged.

Warning: Do not locate multiple portable socket-outlets or portable power supplies at the rear of the appliance.

Do not use extension cords or ungrounded (two prong) adapters.

Danger: Risk of child entrapment. Before you throw away your old refrigerator or freezer:

–Take off the doors.

–Leave the shelves in place so that children may not easily climb inside.

The refrigerator must be disconnected from the source of electrical supply before attempting the installation of accessory.

Refrigerant and cyclopentane foaming material used for the appliance are flammable. Therefore, when the appliance is scrapped, it shall be kept away from any fire source and be recovered by a special recovering company with corresponding qualification other than be disposed by combustion, so as to prevent damage to the environment or any other harm.

The necessity that, for doors or lids fitted with locks and keys, the keys be kept out of the reach of children and not in the vicinity of the refrigerating appliance, in order to prevent children from being locked inside.

For EN standard: This appliance can be used by children aged from 8 years and above and persons with reduce physical sensory or mental capabilities or lack of experience and knowledge if they have been given supervision or instruction concerning use of the appliance in a safe way and understand the hazards involved. Children shall not play with the appliance. Cleaning and user maintenance shall not be made by children without supervision. Children aged from 3 to 8 years are allowed to load and unload refrigerating appliances.

To avoid contamination of food, please respect the following instructions:



- Opening the door for long periods can cause a significant increase of the temperature in the compartments of the appliance.
- Clean regularly surfaces that can come in contact with food and accessible drainage systems.
- Clean water tanks if they have not been used for 48 h; flush the water system connected to a water supply if water has not been drawn for 5 days. (note 1)
- Store raw meat and fish in suitable containers in the refrigerator, so that it is not in contact with or drip onto other food.
- Two-star ** frozen-food compartments are suitable for storing pre-frozen food, storing or making ice-cream and making ice cubes. (note 2)
- One * -, two ** , three-star *** -and four-star **** compartments are not suitable for the freezing of fresh food. (note 3)
- For appliances without a 4-star compartment: this refrigerating appliance is not suitable for freezing foodstuffs. (note 4)
- If the refrigerating appliance is left empty for long periods, switch off, defrost, clean, dry, and leave the door open to prevent mould developing within the appliance.

Note 1,2,3,4: Please confirm whether it is applicable according to your product compartment type.

For a freestanding appliance: this refrigerating appliance is not intended to be used as a built-in appliance.

Any replacement or maintenance of the LED lamps is intended to be made by the manufacturer, its service agent or similar qualified person.

1.2 Meaning of safety warning symbols

	The symbols indicate prohibited matters, and those behaviors are forbidden. Non-compliance with the instructions may result in product damages or endanger the personal safety of users.
	The symbols indicate matters that must be followed, and those behaviors must be strictly executed in line with the operation requirements. Non-compliance with the instructions may result in product damages or endanger the personal safety of users.
	The symbols indicate matters to pay attention to, and these behaviors shall be specially noted. Due precautions are needed or minor or moderate injuries or damages of the product will be caused.

This manual contains lots of important safety information which shall be observed by the users.

1.3 Electricity related warnings

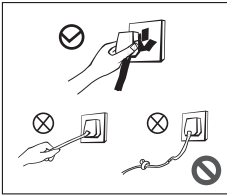

- Do not pull the power cord when pulling the power plug of the beverage cellar . Please firmly grasp the plug and pull out it from the socket directly.
- Do not damage the power cord under any condition so as to ensure safety use, do not use when the power cord is damaged or the plug is worn.
- Worn or damaged power cord shall be replaced in manufacturer-authorized maintenance stations.

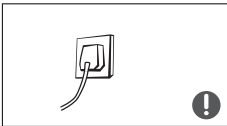

- The power cord should be firmly contacted with the socket or else fires might be caused. Please ensure that the grounding electrode of the power socket is equipped with a reliable grounding line.



- Please turn off the valve of the leaking gas and then open the doors and windows in case of leakage of gas and other flammable gases. Do not unplug the cellar and other electrical appliances considering that spark may cause a fire.

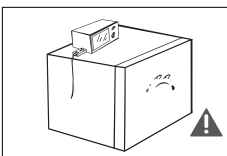

- To ensure safety, it is not recommended that to place socket, regulators, rice cookers, microwave ovens and other appliances at the top of the beverage cellar, those recommended by the manufacturer are not included. Do not use electrical appliances in the food pantry.

1.4 Related warnings for use

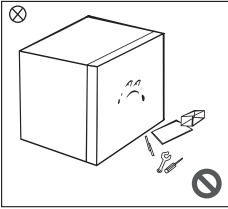

- Do not arbitrarily disassemble or reconstruct the beverage cellar, nor damage the refrigerant circuit; maintenance of the appliance must be conducted by a specialist.
- Damaged power cord must be replaced by the manufacturer, its maintenance department or related professionals in order to avoid danger.

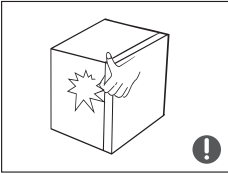

- The gaps between cellar door and cellar body are small, be noted not to put your hand in these areas to prevent from squeezing the finger. Please be gentle when close or open the cellar door to avoid falling articles.

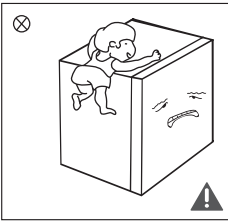

- Do not give package and other components to children to play. The bending board and plastic film may lead to suffocation! Do not allow children to enter or climb the cellar to prevent that children are sealed in the cellar or children are injured by the falling cellar.
- Do not spray or wash the cellar; do not put the cellar in moist places easy to be splashed with water so as not to affect the electrical insulation properties of the cellar.
- Do not use cellar body, cellar door, etc. as pedal or support.

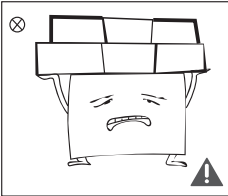

- Do not place heavy objects on the top of the cellar considering that objects may fall when open or close the door, and accidental injuries might be caused.
- Please pull out of the plug in case of power failure or cleaning. Do not connect the cellar to power supply within five minutes to prevent damages to the compressor due to successive starts.

1.5 Warnings related to placing items

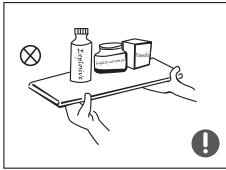

- Do not put flammable, explosive, volatile and highly corrosive items in the cellar to prevent damages to the product or fire accidents.
- Do not place flammable items near the cellar to avoid fires.

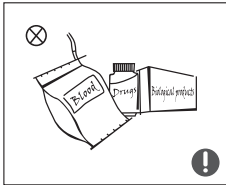



- This product is for household refrigeration appliances, mainly used in the storage of beverage, not for other purposes, such as storage of blood, drugs and biological products.

1.6 Warnings for energy

- 1) Beverage cellar might not operate consistently when sited for an extended period of time below the cold end of the range of temperatures for which the cellar appliance is designed.
- 2) The need to not exceed the storage time(s) recommended by the beverage manufacturers for any kind of beverage.
- 3) The precautions necessary to prevent an undue rise in the temperature of the beverage while defrosting the beverage cellar.
- 4) The fact that a rise in temperature of the beverage during manual defrosting, maintenance or cleaning could shorten the storage life.

1.7 Warnings related to disposal

 Refrigerant and cyclopentane foaming material used for the beverage cellar are flammable. Therefore, when the beverage cellar is scrapped, it shall be kept away from any fire source and be recovered by a special recovering company with corresponding qualification other than be disposed by combustion, so as to prevent damage to the environment or any other harm.

 When the beverage cellar is scrapped, disassemble the doors, and remove gasket of door and shelves; put the doors and shelves in a proper place, so as to prevent trapping of any child.



Correct Disposal of this product:

This marking indicates that this product should not be disposed with other household wastes. To prevent possible harm to the environment or human health from uncontrolled waste disposal, recycle it responsibly to promote the sustainable reuse of material resources. To return your used device, please use the return and collection systems or contact the retailer where the product was purchased. They can take this product for environmental safe recycling.

2 Proper use of the cellar

2.1 Names of components

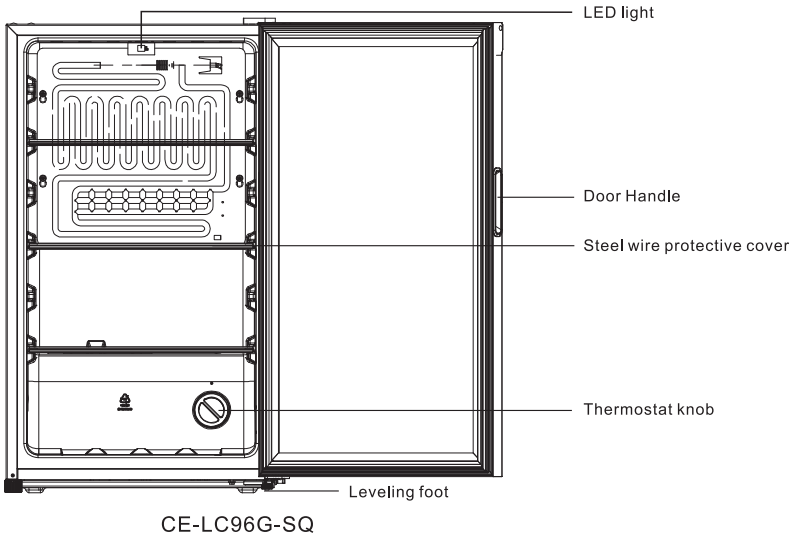
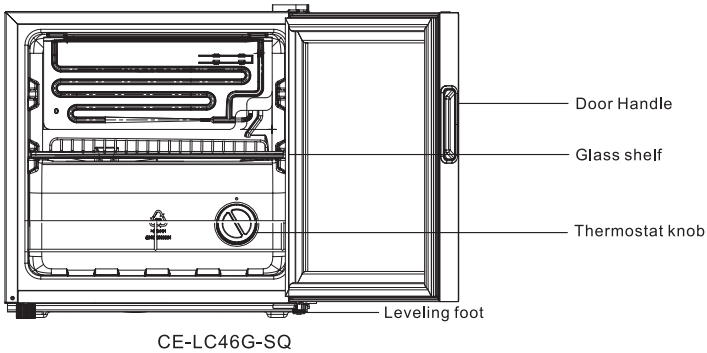

(The picture above is only for reference. The actual configuration will depend on the physical product or statement by the distributor)

- Shelf in accordance with the factory state placed the most energy – saving.
There is no need to turn on the light when working normally.
- The cellar is mainly used for storing drinks.
Do not place food in the cellar to prevent bacterial contamination.
- Please keep the interior of the cellar dry.

2.2 Temperature Control

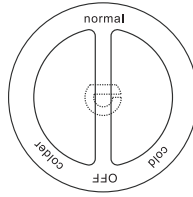

(The picture above is only for reference. The actual configuration will depend on the physical product or statement by the distributor)

Recommended gear: "normal"

After power-on the beverage cellar, it is able to turn the temperature controlling knob to set the temperature level. "Cold" is the warmest setting, "Colder" is the coldest setting, "OFF" means stop running.

2.3 Placement

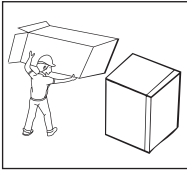

- Before using the cellar, remove all packaging materials including bottom cushions and foam pads and tapes inside the cellar. Tear off the protective film on the door and the cellar body.

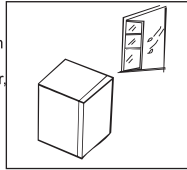

- The cellar is placed in a well-ventilated indoor place; the ground shall be flat, and sturdy (rotate left or right to adjust the leg for levelling if unstable).

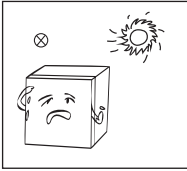

- Avoid direct sunlight and heat sources such as stove, heating radiator, etc. If the cellar has to be put next to heat source, a suitable insulation board shall be applied or keep the cellar away from heat source.

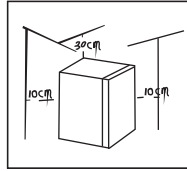

- The top space of the cellar shall be greater than 30cm, and the distances from both sides and backside shall be more than 10cm to facilitate heat dissipation.

2.4 Start to use

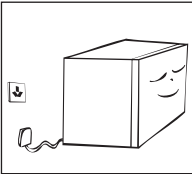

- The cellar shall stay for half an hour before connecting power when it is firstly started.
- Clean up the inner chamber before put into use for first time .
- Do not connect cellar to electronic energy saving plug and converter that can convert DC into AC (E.g.: solar energy system, ship grid).
- Water drop or frost will be generated on backside of beverage cellar when compressor is running, which is decided by function of cellar. Wiping out frost or water drop is not needed as the back will wipe them out automatically. The defrosted water will be collected into drain tank, then inflow into water disposal pan above the compressor and vaporized.

2.5 The arrangement of bottle

Do not let bottle touch the cellar's back in order to maintain good air circulation in the cellar.

The bottle number may be different from bottles in different shape and size. Oversized bottle may have impact on the number of bottle storage in the beverage cabinet.

2.6 Usage of temperature zones inside the cellar

Due to different temperature zones generated due to air circulation in the cooler, the upper area's temperature is higher than the lower area.

2.7 Energy saving tips

- The cellar shall be placed in room dry and ventilated. The cellar be put under direct sunlight or next to heat source (such as radiator, stove, etc.) and a suitable insulation board shall be applied if necessary.
- Try to shorten opening time of cellar's door.
- Put beverage into cellar after it has cooled down.

2.8 According to certification requirements, the storage temperature range of this product is as follows:

FOR EN 62552:2013: 8–14°C ;
FOR EN 62552:2020: 5–14°C

2.9 Reversing the door swing

1. Change the installation location of the upper hinge^⑤ of the beverage cabinet, then the opening direction of the door could be changed at will. Please follow the following instructions for the change of the opening direction of the beverage cabinet's door (for instance: from right-handed door to left-handed door): close the glass door of the beverage cabinet, use a blade to remove the rivet^② carefully, loose the mounting cover^③ of the door hinge and three positioning bolts^④ and remove the upper hinge^⑤.

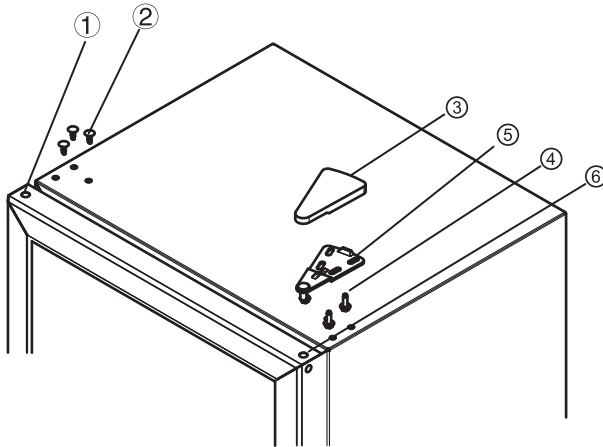

2. Open the door of the beverage cabinet and detach the glass door of which with tremendous care.

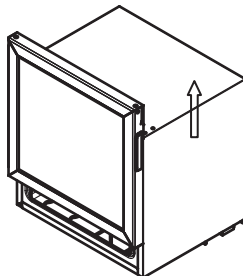

3. Dismantle the door axle sleeve⑥at lower part of the glass door, door stopper block screws⑧and door stopper⑦, and fix them to left side.

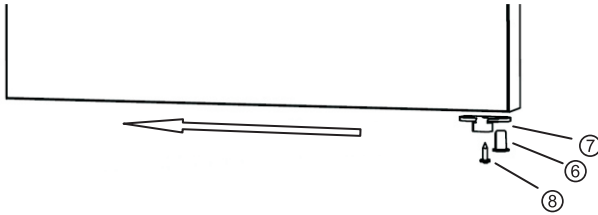

4. Dismantle the adjustable foot⑪, positioning bolts④and lower hinge⑩, then exchange the parts of right and left sides and later use the reverse method to install the adjustable foot, lower hing and positioning bolts.

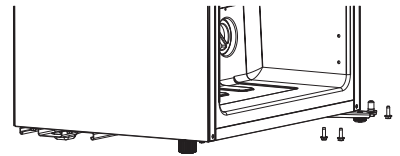
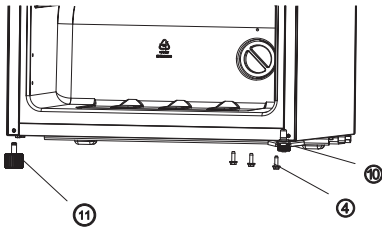

5. Put the aforesaid glass door on the lower hinge, and fix the upper hinge⑤. Align the door with the cabinet and check the tightness of gasket, and then install all the ornaments②③.

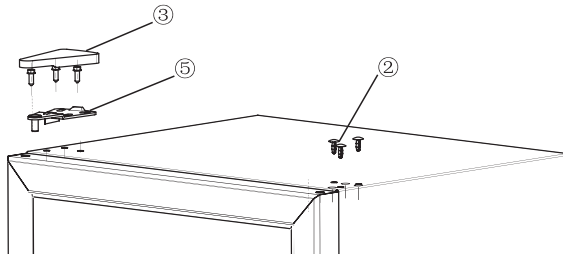

(The picture above is only for reference. The actual configuration will depend on the physical product or statement by the distributor)

3 Maintenance of the cellar

3.1 Do not use for a short time

Switch gears to OFF, or disconnect the power

3.2 Do not use for a long time

1. Disconnect power plug;
2. Clean the cellar;
3. Keep the cellar door open.

3.3 Clean the cellar

- Dusts behind the cellar and on the ground shall be timely cleaned to improve the cooling effect and energy saving.
- Check the door gasket regularly to make sure there are no debris. Clean the door gasket with a soft cloth dampened with soapy water or diluted detergent.
- The interior of the cellar should be cleaned regularly to avoid odor.
- Please turn off the power before cleaning interior, remove all foods, drinks, shelves, etc.
- Use a soft cloth or sponge to clean the inside of the cellar, with two tablespoons of baking soda and a quart of warm water. Then rinse with water and wipe clean. After cleaning, open the door and let it dry naturally before turning on the power.
- For areas that are difficult to clean in the cellar (such as narrow sandwiches, gaps or corners), it is recommended to wipe them regularly with a soft rag, softbrush, etc. and when necessary, combined with some auxiliary tools (such as thin sticks) to ensure no contaminants or bacterials accumulation in these areas.
- Do not use soap, detergent, scrub powder, spray cleaner, etc., as these may cause odors in the interior of the cellar or contaminated food.
- Clean the shelves with a soft cloth dampened with soapy water or diluted detergent. Then rinse with water and dry with a soft cloth or dry naturally.
- Wipe the outer surface of the cellar with a soft cloth dampened with soapy water, detergent, etc., and then wipe dry. Do not rub or scratch the surface of the glass door to prevent the door from being broken or scratched.
- Do not use hard brushes, clean steel balls, wire brushes, abrasives (such as toothpastes), organic solvents (such as alcohol, acetone, banana oil, etc.), boiling water, acid or alkaline items, which may damage the cellar surface and interior. Boiling water and organic solvents such as benzene may deform or damage plastic parts.
- Do not rinse directly with water or other liquids during cleaning to avoid short circuits or affect electrical insulation after immersion.



Notice:

Do not use detergent and solvent with sand or acid.

4 Trouble shooting

Inoperation	Whether the cellar is plugged and connected to power; Low voltage; Whether temperature control knob is in the work area; Failure power or tripping circuit.
Long-term operation of compressor	It is normal that cellar operates for longer time in summer when the ambient temperature is higher; Do not put too much beverage s in the cellar at one time; Frequent opening of cellar door.
Illuminating light does not shine	Whether the cellar is connected to power, whether the indicator light is damaged.
Loud noises	Whether the floor is flat, whether the placement of cellar is stable; Whether the cellar accessories are properly placed.
cellar enclosure heat Condensation	The cellar enclosure may emit heat during running specially in summer, this is caused by the radiation of the condenser, and it is a normal phenomenon. Condensation: condensation phenomenon will be detected on the exterior surface and door seals of the cellar when the ambient humidity is high, this is a normal phenomenon, and after wiping with towel, turns up the set temperature of the cellar properly.
Airflow sound Buzz Clatter	Refrigerants circulating in the refrigerant lines will produce eruption of sound and grunts which is normal does not affect the cooling effect. Buzz will be generated by running compressor specially when starting up or shutting down.