

Thank you for purchasing our sliding gate opener. We are sure that the products will be greatly satisfying as soon as you start to use it.

The product is supplied with a user's manual which encloses installation and safety precautions. These should be read carefully before installation and operation as they provide important information about safety, installation, operation and maintenance. This product complies with the recognized technical standards and safety regulations.

General Safety

⚠ WARNING! An incorrect installation or improper use of the product can cause damage to persons, animals or properties.

- Scrap packing materials (plastic, cardboard, polystyrene etc.) according to the provisions set out by current standards. Keep nylon or polystyrene bags out of children's reach.
- This product was exclusively designed and manufactured for the use specified in the present documentation. Any other use not specified in this documentation could damage the product and be dangerous.
- The factory declines all responsibility for any consequences resulting from improper use of the product, or use which is different from that expected and specified in the present documentation.
- Do not install the product in explosive atmosphere.
- The factory declines all responsibility for any consequences resulting from failure to observe Good Technical Practice when constructing closing structures (door, gates etc.), as well as from any deformation which might occur during use.
- Disconnect the electrical power supply before carrying out any work on the installation. Also disconnect any buffer batteries, if fitted.
- Fit an omnipolar or magnetothermal switch on the mains power supply, having a contact opening distance equal to or greater than 3,5 mm.
- Make sure a residual current circuit breaker with a 30mA threshold is fitted before the power supply mains.
- Check that earthing is carried out correctly: connect all metal parts for closure (doors, gates etc.) and all system components provided with an earth terminal.
- Fit all the safety devices (photocells, electric edges etc.) which are needed to protect the area from any danger caused by squashing, conveying and shearing.
- Position at least one visible indication device (Alarm lamp), and fix a Warning sign to the structure.

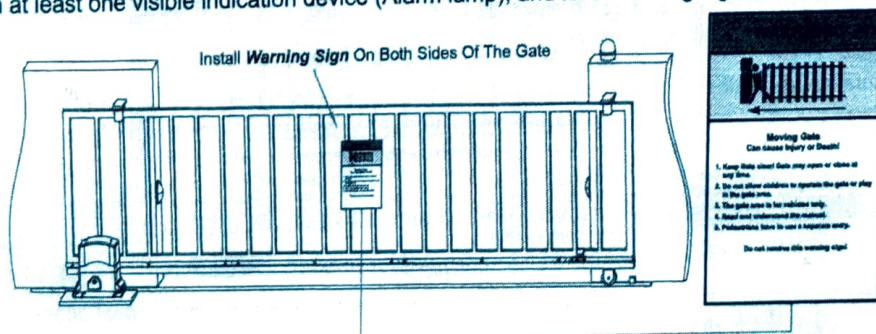

- The factory declines all responsibility with respect to the automation safety and correct operation when other supplier's components are used.
- Only use original parts for any maintenance or repair operation.
- Do not modify the automation components, unless explicitly authorized by the factory.
- Instruct the product user about the control systems provided and the manual opening operation in case of emergency.

- Do not allow persons or children to remain in the automation operation area.
- Keep radio control or other control devices out of children's reach, in order to avoid unintentional automation activation.
- The user must avoid any attempt to carry out work or repair on the automation system, and always request the assistance of qualified personnel.
- Anything which is not expressly provided for in the present instructions is not allowed.
- Before installing the gate opener, check that all moving part as well as the sliding gate is in good mechanical condition, correctly balanced and opens and closes properly.
- Save these instructions for future use.

Preparation for Installation

Before proceeding to your opener installation, check if your gate structure is in accordance with the current standards, especially as follows:

The gate sliding track is linear and horizontal. The wheels are suitable for use. The gate should be mounted and moved freely. Check that the structure is sufficiently strong and rigid, and that its dimensions and weights conform to those listed in the specifications table of this document. Make sure that the gate is plumb and level. The fence posts must be mounted in concrete. The gate does not bind or drag on the ground.

- The gate manual operation can be carried out smoothly along its entire run, and there is no excessive side slipping.
- The opening and closing gate stops are positioned.



WARNING: Remember that control devices are intended to facilitate gate operation, but can not solve problems due to any defects or deficiency resulting from failure to carry out correct installation or maintenance. Take the product out of its packing and inspect it for damage. Should it be damaged, contact your dealer. Remember to dispose of its components (cardboard, polystyrene, nylon, etc.) according to the current prescriptions.

Refer to the following Figures for gate installation.

Using the post or wall as a stop, either directly or indirectly, is not recommended so as to protect the post or wall against damaging shock from the sliding gate.

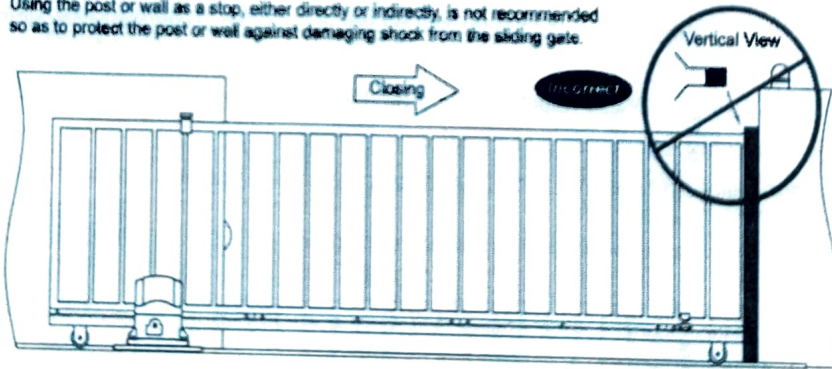



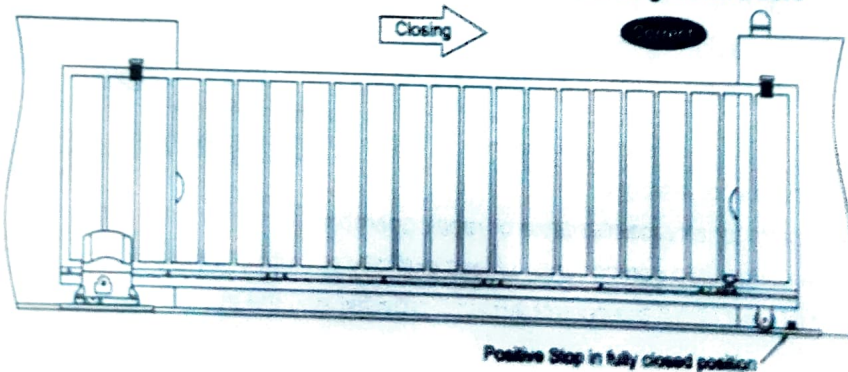

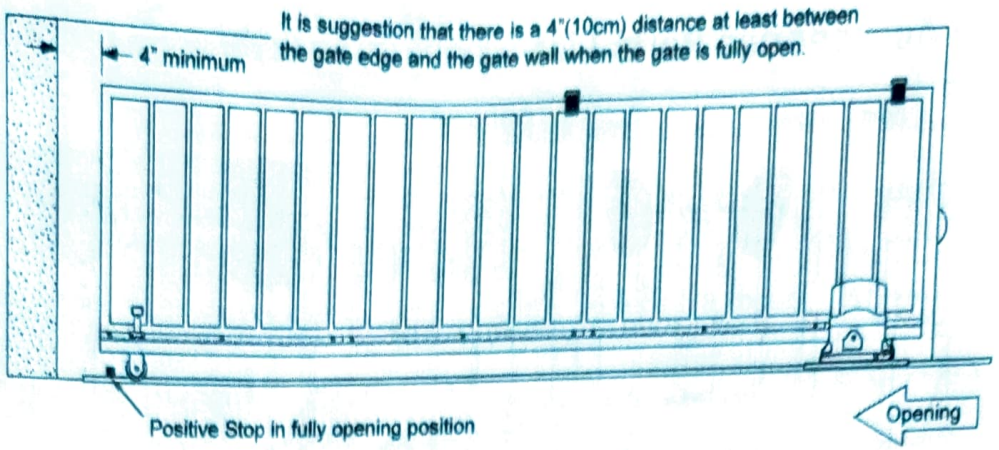



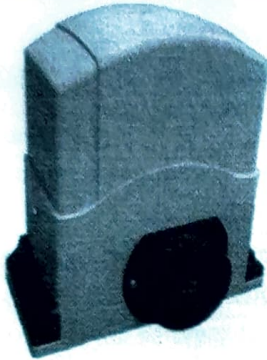

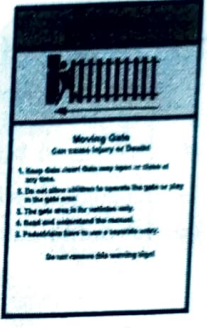





In sake of safety, a positive stop must be mounted on the two end of ground track.













Parts List

 <p>Gate Opener (1 pc)</p>	 <p>Key (2 pcs)</p>	 <p>Expansion Bolt (4 pcs)</p>	 <p>Warning Signs (2 pcs)</p> <p>Warning Gate Can cause injury or death!</p> <ol style="list-style-type: none"> 1. Heavy duty closed gate may injure or crush if not fully open. 2. Do not allow children to operate the gate or play in the gate area. 3. The gate area is for vehicles only. 4. Read and understand the manual. 5. Prohibit gate to use a separate entry. <p>Do not remove this warning sign!</p>
 <p>Hex Bolt M8x30 (4 pcs)</p>	 <p>Pan Head Screw M5x12 (8 pcs)</p>	 <p>Higher Magnet bracket (1 pc)</p>	 <p>Lower Magnet bracket (1 pc)</p>
 <p>Spring Washer $\phi 8$ (4 pcs)</p>	 <p>Plain Washer $\phi 8$ (4 pcs)</p>	 <p>Magnet Assembly Red (1 pc)</p>	 <p>Magnet Assembly Blue (1 pc)</p>
 <p>Light Duty Plastic Rack Reinforced with Steel 1005mmxN(pcs) (Optional)</p>		 <p>Heavy Duty Plastic Rack Reinforced with Steel 1005mmxN(pcs) (Optional)</p>	
 <p>Galvanized Steel Rack 1005mmxN(pcs) (Optional)</p>	 <p>Steel Gear (1pc) (Optional)</p>	 <p>Remote Control (2 pcs)</p>	

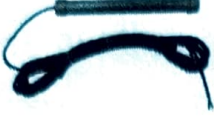
Optional Accessories Parts List

Optional				
 Alarm Lamp (1 pc) (LM141)	 PhotoCell Beam System (1 set) (LM102)	 Wall push button (1 pc) (LM147)	 Wireless push button (1 pc) (LM173)	 Wireless Keypad (1 pc) (LM172)
 Mounting post for keypad (1 pc) (LM107)	 Exit Wand (1 pc) (LM157)	 3.5" Video Intercom (1 set) (LM162)	 External Receiver (1 pc) (LM138)	

Technical Specifications & Features

Specifications		
	SFG-18H	SFG-21H
Power supply:	120V/60HZ or 230V/50HZ	
Motor voltage:	120VAC or 230VAC	
Absorbed power:	370W	550W
Gate moving speed:	20 cm/second	
Max gate weight:	800KGS	1200KGS
Max torque:	24Nm	35Nm
Environmental conditions:	From -15°C to +40°C	
Protection class:	IP44	

Features:

- Easy to install and low maintain.
- Midway mode
- Quick selection for gate open/close direction
- Reliable rolling code technology
- Emergency release key in case of power failure
- Stop in case of obstruction during gate opening
- Reverse in case of obstruction during gate closing
- Built in adjustable auto-closing ((0, 30, 60, 90 seconds)
- Built in max. Motor running time (MRT) adjustable for multiple safety protection (90 seconds)
- Reliable electromagnetism limit for easy adjustment
- Can be equipped with wide range accessories

Installation Overview

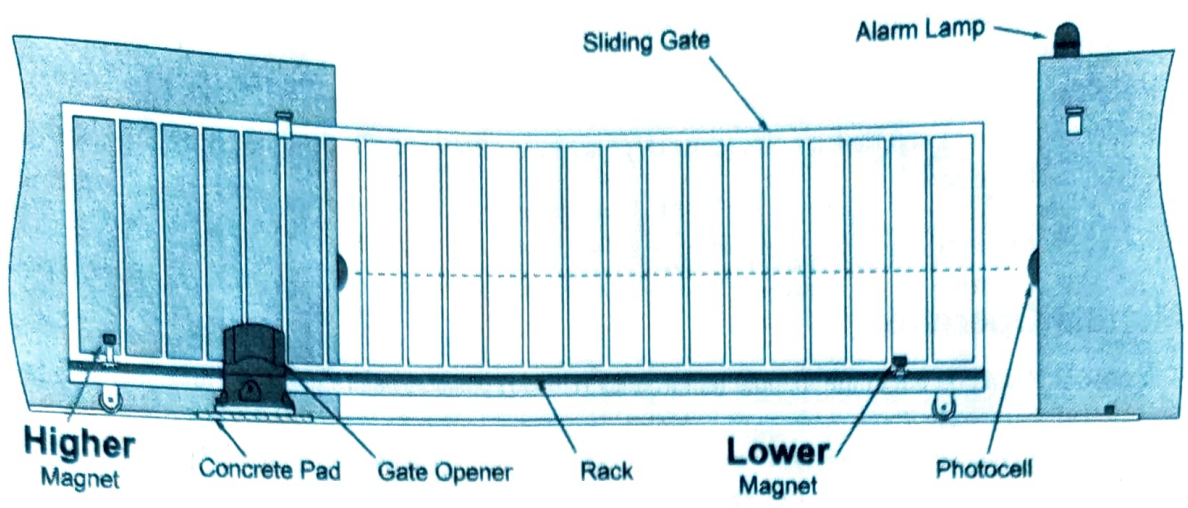

Installation of the Opener

Caution:

*Be sure that the opener is installed in a level and paralleled position and is properly secured. Improper installation could result in property damage, severe injury, and/or death.

* Before starting installation, ensure that there is no point of friction during the entire movement of the gate and there is no danger of derailment.

* Ensure that the safety side panels are present.

Necessary Tools: The following tools may be necessary to install the Gate opener. You will need screwdrivers, an electric drill, wire cutters and a wire stripper, a socket set, and possibly access to a welder.

When install the opener, you should build a concrete pad to support the base plate of opener in order to maintain proper stability.

The installation proceeds are as follows:

1. Dig a hole for a concrete pad which should be approximately 50 x 30 x 35cm (20" x 12" x 14"). It may protrude 10 cm (4") above ground and 25 cm (10") in depth underground. Increase the pad height if necessary to protect the system from flooding, heavy snow etc.

2. Prepare one or more conduits for the electrical cables before pour concrete. Remember that cable conduits have to pass through the hole in the base plate.

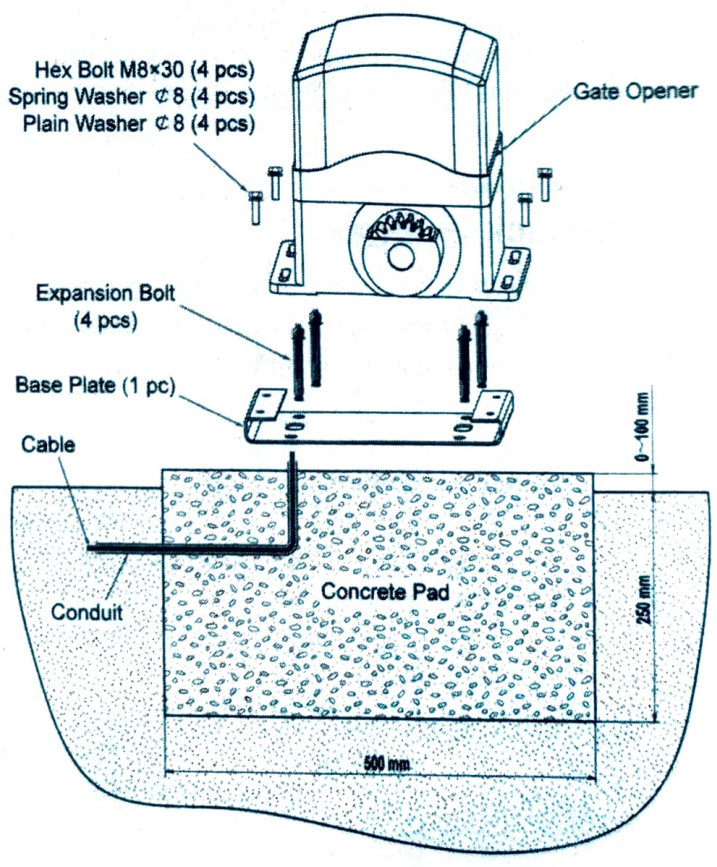

3. Pour concrete and before it starts to harden, check that it is parallel to the gate leaf and perfectly level.
4. Mark the position of four expansion anchors according to the position of mounting hole on the base plate as soon as concrete become harden. Double check your marking, move the base plate and drill the 4 holes using a 10mm (3/8") masonry bit. Put the 4 expansion anchors (provided) into the holes and firmly tighten.
5. Place the opener onto base plate. Check that it is perfectly parallel to the gate leaf, and then screw the four nuts and washers supplied. It's only temporary installation. Further adjustment will be required when install the rack or chain.

Manual Operation

The opener should be put in the manual (emergency release) position before fitting the rack, installing the opener and limit switch. The process is as follows:

- 1) Insert and turn the key clockwise 45° to slide the lock cover. Now the key slot appears.
- 2) Insert the T-handle Key (provided) to the key slot and turn it in counter-clockwise 135° to disengage the clutch between the gear shaft and power output. Now the opener is in the manual operation.

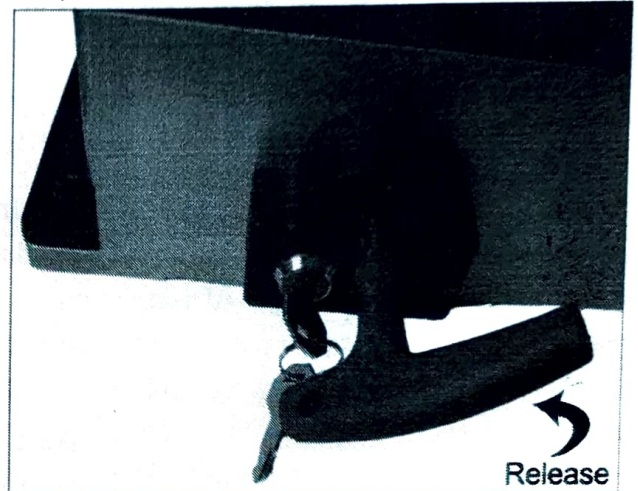
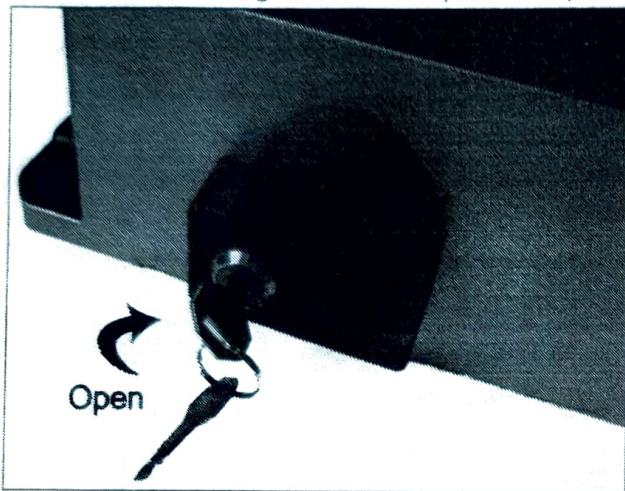

Fit the Rack

There are two kinds of rack available as per buyer's option, which are steel reinforced plastic rack and galvanized steel rack. The galvanized steel rack is usually used for the heavy duty gate.

A. Fit the plastic rack reinforced with steel

1. Start with gate in closed position
2. There are four sections of plastic rack which is one meter length, each section for standard package. (you can order extra rack from dealer if necessary)
2. Put one end of rack section on the gear of opener as a temporary support. Make rack level and mark the rack's mounting holes (four holes) on the gate.
3. Fit the rack by self-threading screws. This kind of plastic rack is quieter and allows height adjustments to be made even after it has been fixed. Please keep 1.0mm space between the rack and the gear to avoid the weight of the gate leaf effect on the opener.

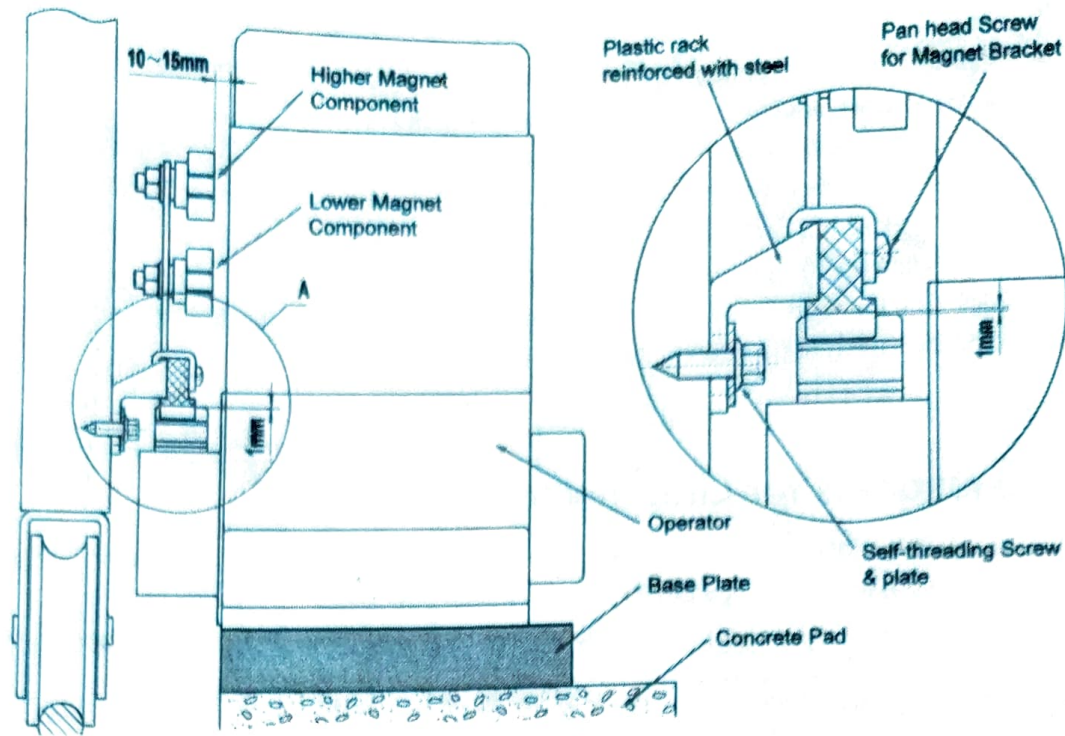

B. Fit the galvanized steel rack

1. Start with gate in closed position
2. There are four sections of steel rack which is one meter length, each section for standard package. (you can order extra rack from dealer if necessary)
2. Put one end of rack section on the gear of opener as a temporary support. Make rack level and mark the rack's mounting holes (three holes) on the gate.
3. Weld the rack nut on the gate as mark and connect the rack to the gate using the bolt provided. Before weld, please keep 1.0mm space between the rack and the gear to avoid the weight of the gate leaf effect on the opener.

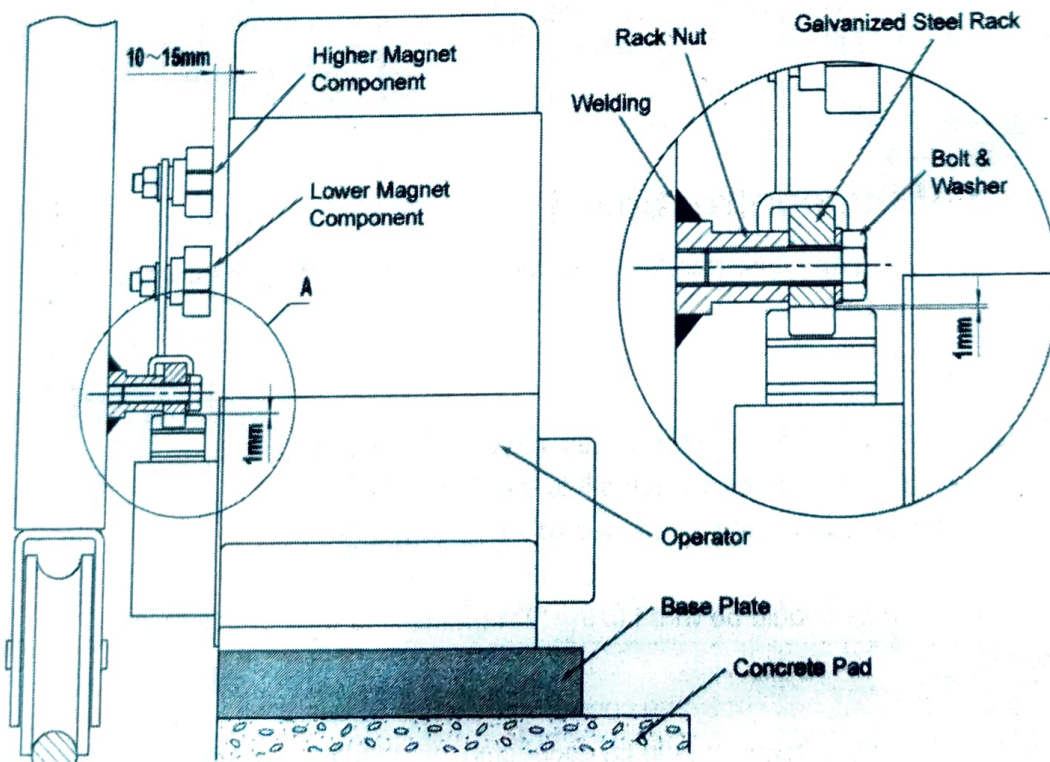

Important:

- * Check that the rack teeth must engage the gear teeth throughout their full thickness. If not, adjust the position of the opener or/and place a few shims between the rack and gate.
- 4. Manually slide the gate leaf to ensure the rack is proper on the gear of opener, weld the second nut.
- 5. Repeat same steps of first rack section to install the rest rack sections until proper length is reached.
- 6. Cut away any excess of the rack (Note: rack length must be longer than actual travel of the gate to accommodate limit switch brackets on each gate side.)
- 7. Thoroughly fasten the four nuts as well as spring washers onto expansion bolt tightly, enabling the opener is firmly secured on the concrete pad during the whole gate travel.

Install the magnets for Limit Switches

Before install limit switch, make sure the gate opener is put in manual operation. (the clutch connected with gear shaft is disengaged) and the mains power supply is disconnected.

Position the two limit stop brackets approximately on the rack and move the gate by hand to fix them in place.

Fit magnets bracket

Push the gate fully closed by hand. Locate and install the magnet bracket so that the opener will stop at the desired close position when the close limit switch approaches it.

Push the gate fully open by hand. Locate and install the magnet bracket so that the opener will stop at the desired open position when the open limit switch approaches it.

The higher magnet bracket must be installed at left side and lower magnet bracket must be installed at right side from the view inside of property. Finally adjust the magnet to the proper position by moving the gate with the motor. **The magnet should be 20-30mm away from the magnetic limit switch.** If it is too far away, the switch will fail to work. The distance between the magnet and the opener should be 10-15mm with the opener cover on. Adjust the position of the magnet until the positions of the opening and closing meet the requirement.

Important Note: Please note the two magnet brackets (fixed plate) are different: one is higher and the other is lower.

Connecting of the control board

⚠ Warning: Before making any electrical wire connection or/and setting the control board, make sure that the power switch is OFF.

1. Motor

The **BLACK** wire of the motor should be connected into the "6" terminal.

The **RED** wire of the motor should be connected into the "7" terminal.

The **YELLOW** wire of the motor should be connected into the "8" terminal.

2. Start Capacitor

One pin of the start capacitor should be wired to the "7" terminal, another to "8" terminal.

3. Limit Switches

The **RED** wire of the limit switches should be connected into the "9" terminal.

The **BLACK** wire of the limit switches should be connected into the "10" terminal.

The **YELLOW** wire of the limit switches should be connected into the "11" terminal.

Control Board

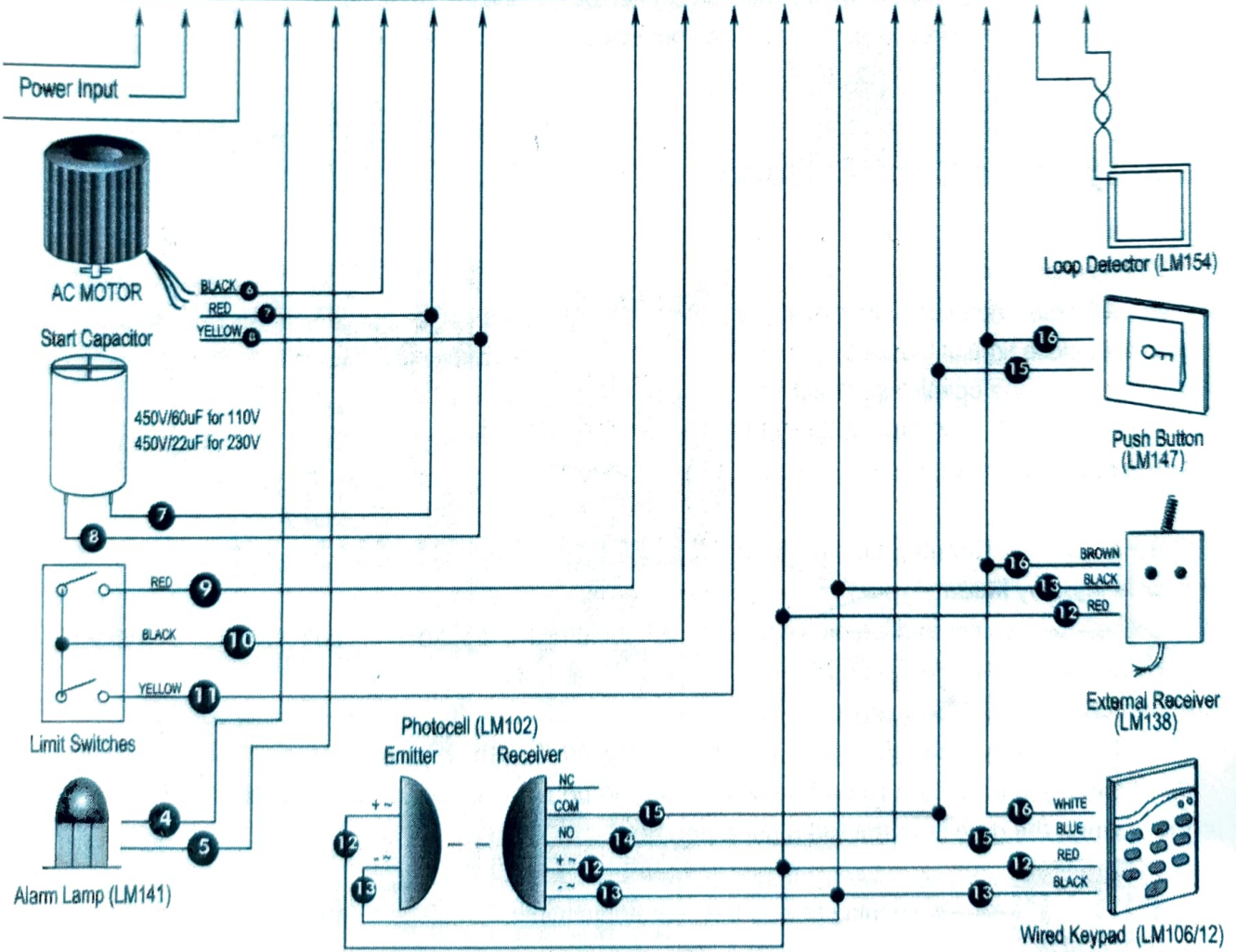
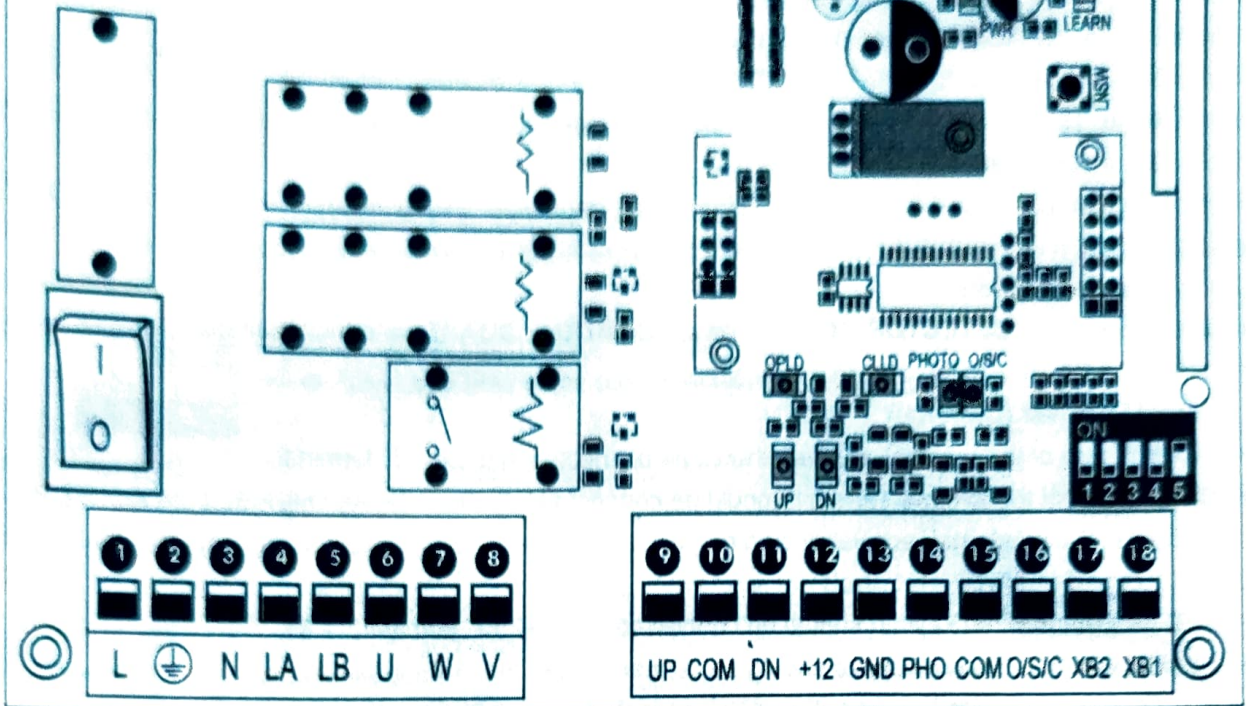

4. Alarm Lamp (Optional)

One wire of the alarm lamp should be connected into the "4" terminal, another should be connected into the "5" terminal.

5. Photocell (Normal Open) (Optional)

Use a 2-core cable to connect the "+ ~" terminal of the photocell's emitter to the "12" terminal, the "- ~" terminal to the "13" terminal. Also the "+ ~" and "- ~" terminals of the photocell's receiver should be connected to the "12" and "13" terminals in parallel.

Use another 2-core cable to connect the "NO" terminal of the receiver to the "14" terminal, the "COM" terminal to the "15" terminal.

6. Push Button (Optional)

The push button should be wired to the "15" and "16" terminals. The gate opener works alternately by pushing the button (open-stop-close-stop-open).

7. Loop Detector (Optional)

First insert the **LOOP DETECTOR BOARD** into the **CONTROL BOARD**, and then connect the twisted-pair to the "17" and "18" terminals.

8. External Receiver (Optional)

The **BROWN** wire of the external receiver should be connected into the "16" terminal.

The **BLACK** wire of the external receiver should be connected into the "13" terminal.

The **RED** wire of the external receiver should be connected into the "12" terminal.

9. Wired Keypad (12VDC) (Optional)

The **RED** wire of the wired keypad should be connected into the "12" terminal.

The **BLACK** wire of the wired keypad should be connected into the "13" terminal.

The **WHITE** wire of the wired keypad should be connected into the "16" terminal.

The **BLUE** wire of the wired keypad should be connected into the "15" terminal.

Setting of the Control Board

1. DIP Switches

The DIP switches are used to set the running time of the motor in midway mode, auto close time of the gate opener and fast change the open/close direction which is determined by the position of the gate opener installed.

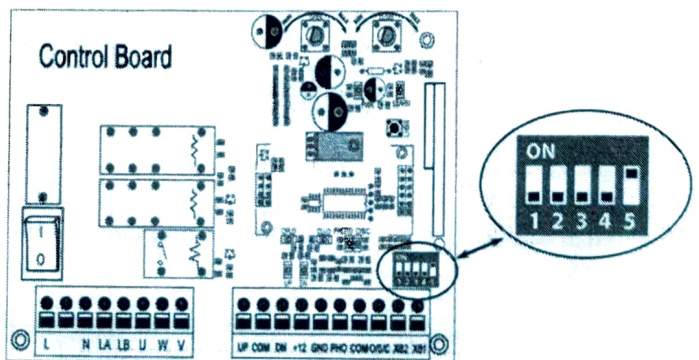

DIP Switch #1-#2: Running time of the motor in Midway Mode

This mode enables user to drive the vehicle through the gate quickly when the gate opens to certain width.

DIP Switch #1: ON – 4 Seconds OFF – 0

DIP Switch #2: ON – 2 Seconds OFF – 0

NOTE: The midway mode function would be disabled if both DIP switches are turned off. Factory default setting is disabled. The midway mode could be activated by pressing button B of the remote control when the gate is in the full closed position.

E.g.  Running time of the operator in midway mode is $4+2=6$ seconds.

Pedestrian mode:

1. Gate in full closed position.
2. DIP Switch 1# or 2# has been set to ON.
3. Press Button "B" of the remote control to open the gate.

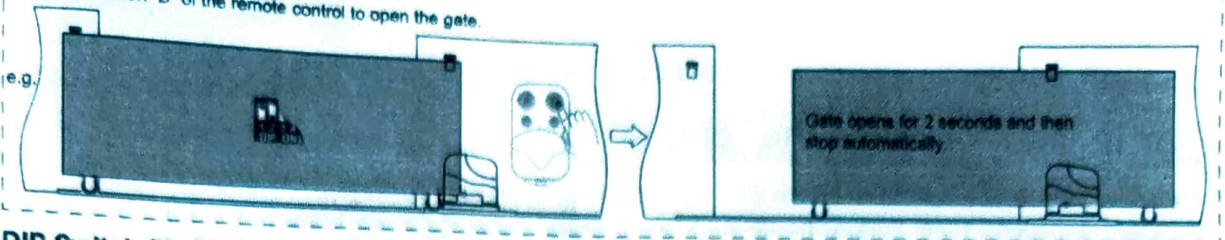

DIP Switch #3-#4: Auto close time of the gate opener

DIP Switch #3: ON - 30 Seconds OFF - 0

DIP Switch #4: ON - 60 Seconds OFF - 0

NOTE: The auto close function would be disabled if both dip switches are turned to off (factory default setting).

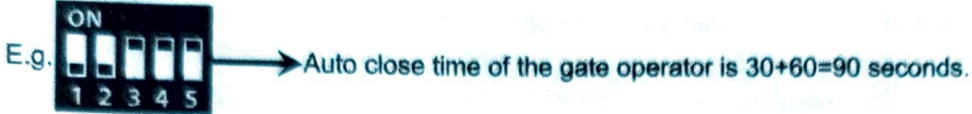

DIP Switch #5: Left/Right open

ON - Left open (factory default setting).

OFF - Right open. Turn switch OFF to change the opening direction easy if necessary.

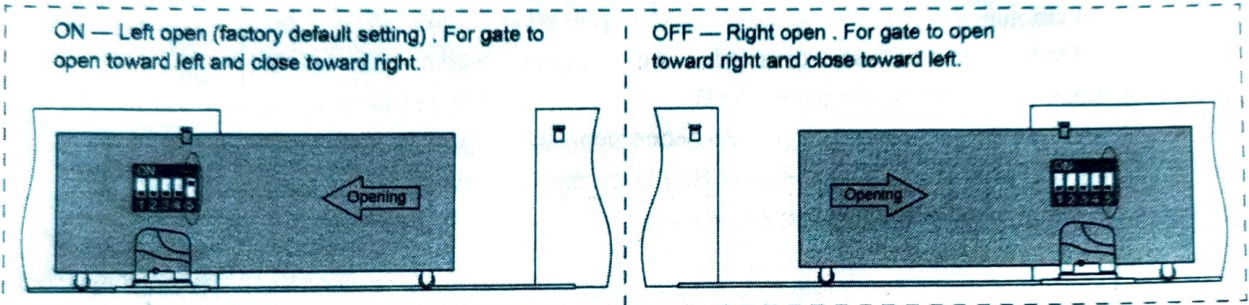

2. Potentiometers

The potentiometer A is to adjust the **OPEN** stall force of the gate opener. The Potentiometer B is used to adjust the **CLOSE** stall force of the gate opener.

Turn the potentiometer clockwise to increase the stall force.

Turn the potentiometer counter-clockwise to decrease the stall force.

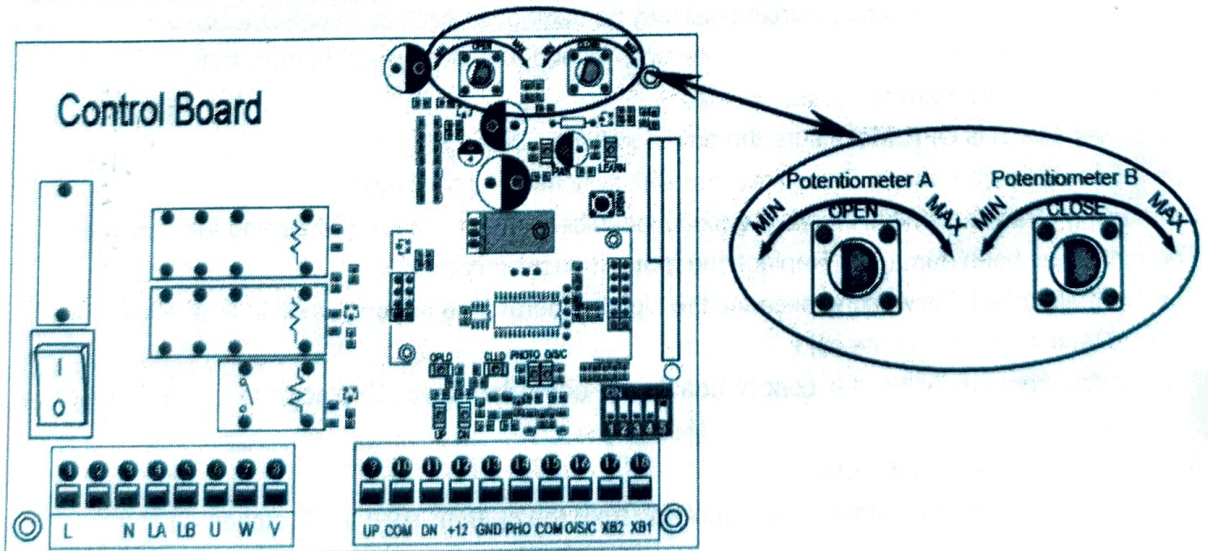

▲ WARNING: Photocell must be installed with the gate opener as entrapment protection for safety when you set stall force to maximum.

How to learn or erase the remote

Learn the remote

Press and release the learn button, the **REM LED** light will be on, then press the key in the remote twice in 2 seconds, the **REM LED** light will flash for 4 seconds. Now the remote has been learnt successfully.

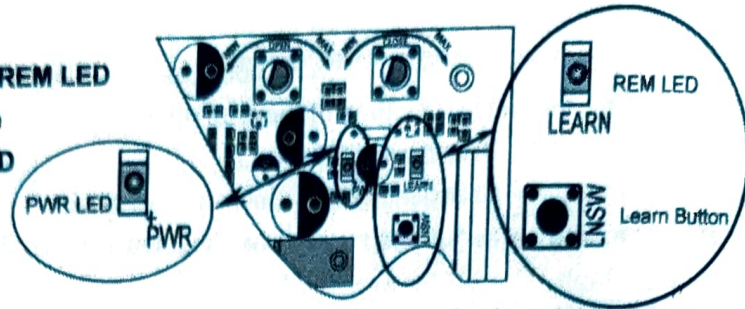

Erase all the remote codes

Press and hold the learn button until the **REM LED** light is off. Now all remote codes have been erased.

How to use the remote to control the opener

Key A is used to operate the opener to work alternately (open-stop-close-stop-open). When the Pedestrian Mode function is enabled, **Key B** is used to achieve the Pedestrian Mode function (open the gate for the pre-setting time). When the Pedestrian Mode function is disabled, the opener works alternately (open-stop-close-stop-open) by pressing **Key B**.

The **Key C** and **Key D** are reserved for garage door opener, swing gate opener in our brand. While if you want to use **Key C** and or **Key D** to control a second sliding gate opener, an external receiver (optional) is necessary.

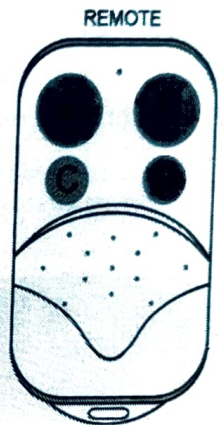

Troubleshooting

Have a multimeter to check voltage and continuity. Use caution when checking high voltage terminals.

1. Motor only runs toward one direction.

- The limit switch is failed. Disconnect the limit switches and try it again.
- The start capacitor of the motor is failed. Replace the capacitor.
- The electric component on the control board may be damaged. Replace the electric component or replace the control board.

2. The gate does not open or close.

- The power switch is OFF. Make sure the power switch is ON.
- The limit switches are failed. Disconnect the limit switches and try it again.
- Connecting wires or terminal blocks are too loose. Check the connecting wires and terminal blocks.
- The motor has been damaged. Replace the motor if necessary.
- The thermal protector is working because the high temperature after long working time. Please wait for 20 minutes to let the motor become cold.
- The electric component on the control board has been damaged. Replace the electric component or replace the control board.

3. Remote control does not work.

- The distance you use the remote is too far away from the opener. Try it again closer.

- b. Remote control is not suitable for receiver. After making sure the codes are correct, erase remote controls and then re-program the codes in the device.
 - c. Broken receive board. Replace receive board.
 - d. The indicator light of remote control is not on. Check the battery in your remote control. Replace the battery if necessary.
- 4. When you open or close the gate by pressing key #1 and key #2 which have been programmed, gate will stop in mid-travel or reverse before reaching the fully limit position.**
- a. The opening force or closing force is adjusted too small. Turn the Potentiometer 1 and 2 to increase the force.
 - b. Gate is obstructed. Remove the obstruction.
- 5. The gate opens, but stops and will not return.**
- a. Please note the two magnet brackets (fixed plate) are different: one is higher and another is lower. Please try to exchange the two brackets position.
 - b. Please try to exchange the limit switch wires CL (close) and OP (open). There are two reed switches inside the magnetic limit switch: one is upper and another is lower. Maybe the magnet position was installed in the middle so it inducts both switches. Adjust the magnet upper or lower.
- 6. The gate can open, but fails to close.**
- a. Photocell is obstructed. Remove obstruction.
 - b. The limit switch is failed. Disconnect the limit switches and try it again.
 - c. The start capacitor of the motor is failed. Replace the capacitor.
 - d. The electric component on the control board has been damaged. Replace the electric component or replace the control board.
- 7. The motor runs but the gate doesn't move.**
- The clutch for emergency release is adjusted properly and is not slipping.

Maintenance

Every six months check the following items for proper operation of the unit.

- * Lubricate shafts and sprockets.
- * Keep opener clean at all times.
- * Check and tighten anchors bolts.
- * Check for loose or corroded wire
- * Ensure the opener is well earthed, and correctly terminated.
- * Always check the Stop/Reverse in case of obstruction function when performing any maintenance. If this function can't be made operable, remove this opener from service until the cause of the malfunction is identified and corrected.